



C-18 CITY SITE SERIES™ ASSEMBLY INSTRUCTIONS

Ref# 2007-638, revised 11-14-07 by MCW

READ ALL INSTRUCTIONS THOROUGHLY
BEFORE YOU BEGIN.

CHECK ALL PARTS

- Be certain there are no missing parts.
- Be certain all required tools are available.

REQUIRED TOOLS

- Driver for 5/32-inch Hex Drive.
- Ratchet or Breaker Bar.
- Socket 5/8-inch or 3/4-inch (dependant on which generation bench is on site.) AND Wrench for 8'
- Towels (or something soft) to rest components on during assembly to protect the finish

ASSISTANCE REQUIRED

- 3 people recommended to assemble product.
 - Necessary to handle, fit, and secure components.
 - Heavy lifting.

All specifications are subject to change. Contact manufacturer for details.
Directions do not include center armrest attachment

DELIVERY, STORAGE, and HANDLING

- Delivery: Deliver products to site in manufacturer's original, unopened containers and packaging. Upon delivery, examine packages immediately to ensure all products are complete and undamaged.
- Storage: Store products in a protected, dry area in manufacturer's unopened containers and packaging
- Handling: Protect product's finish from damage during handling and installation.

INSTALLATION

- Clearance for 3/8-inch (9.53mm) anchor bolts (anchor bolts not provided by Victor Stanley, Inc.)
- Mounting: It is not recommended to locate anchor bolts until bench is in place. This Victor Stanley, Inc. product must be permanently affixed to the ground. Consult your local codes for regulations.

PROTECTION

- Protect products prior to installation by having the remain in The manufacturer's packaging and container.



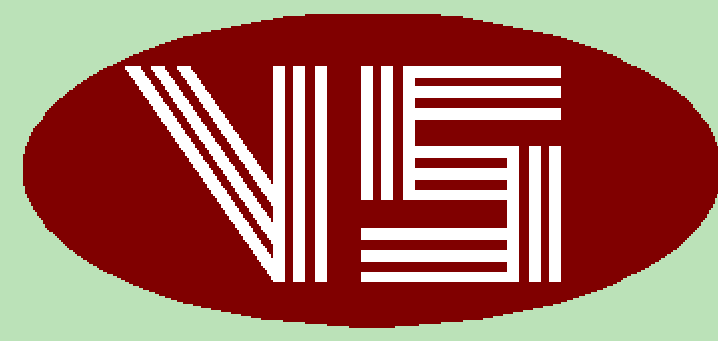

Should you have any problems, please contact Victor Stanley, Inc.

www.victorstanley.com

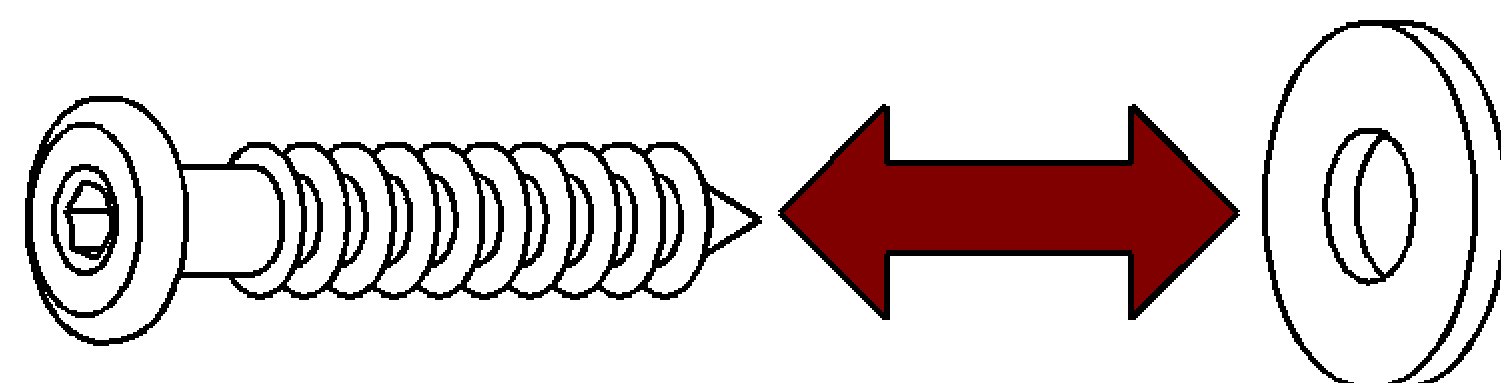
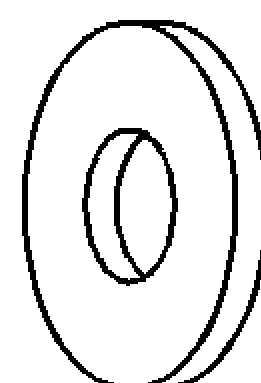

PARTS LIST

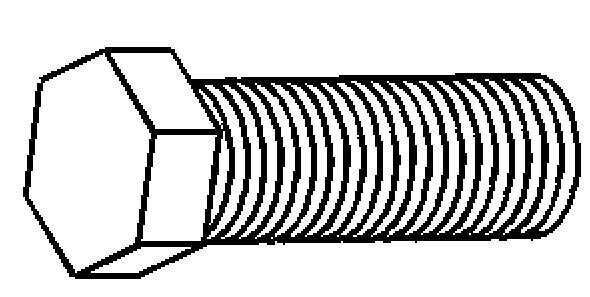
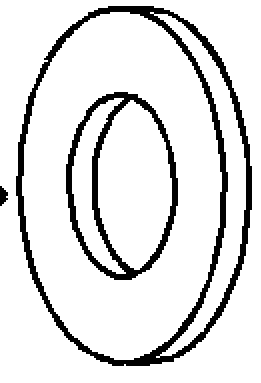
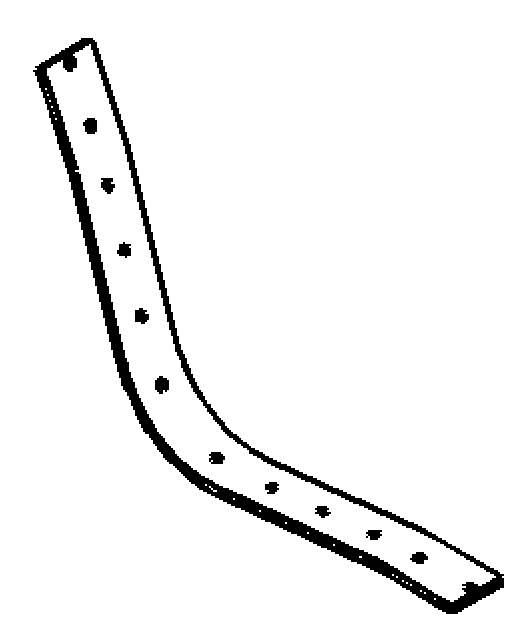
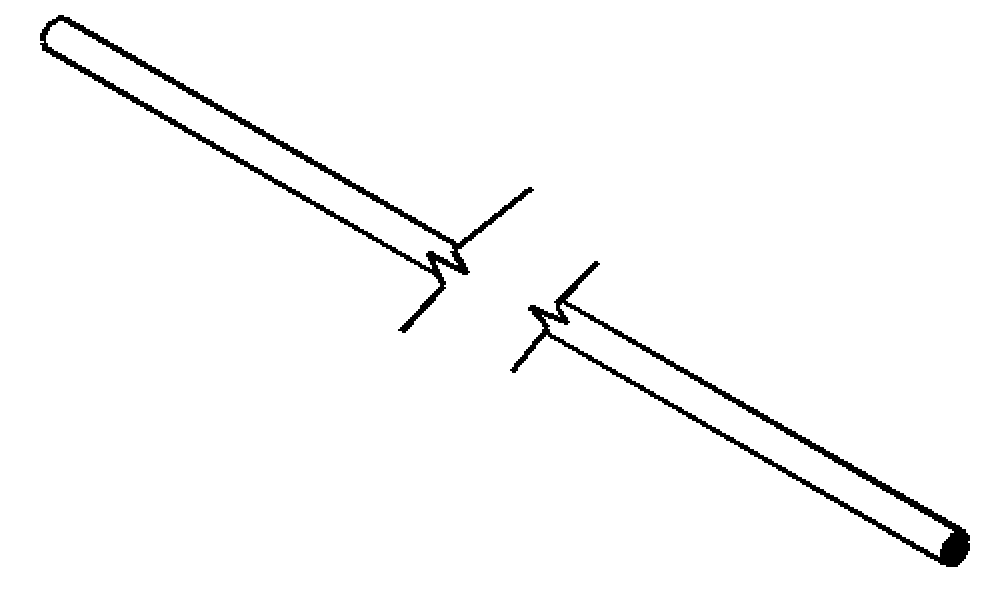
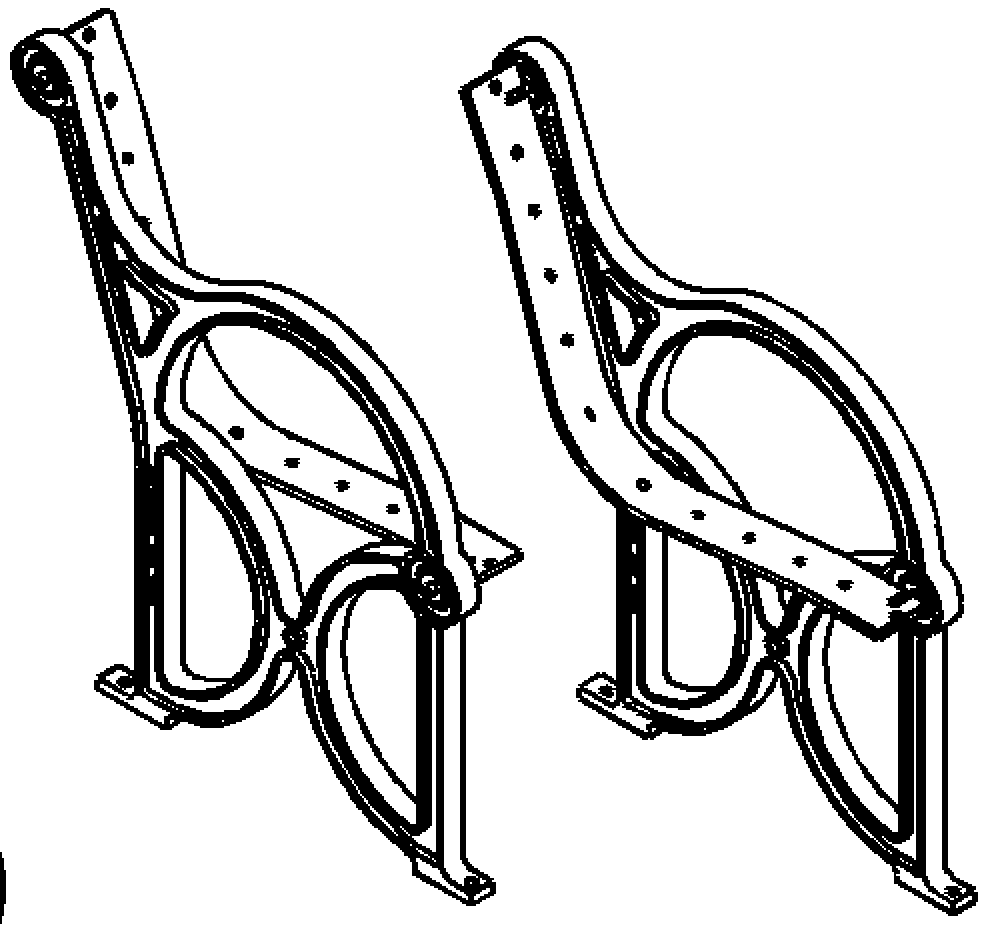
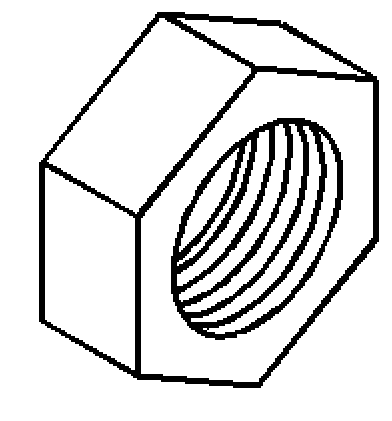
<p>Ax36 Flat Head HEX DRIVE LAG SCREW</p>  <p>Bx36 3/4-inch FLAT WASHER</p> 	<p>Cx1</p>  <p>5/32-inch HEX DRIVE BIT</p>	<p>Dx2 HEX HEAD CAP BOLT (+1 for 8')</p>  <p>Ex2 1-1/8-inch FLAT WASHER (+1 for 8')</p> 
<p>Fx1 Steel CENTER BRACES (8' has welded tab)</p>  <p>Gx1 Tubular Steel CENTER RUNG (8' has welded tab)</p> 	<p>Hx1 CASTINGS (1 LEFT AND 1 RIGHT)</p> 	<p>Jx1 NUT (for 8' only)</p> 

SLAT OPTIONS:

Ix12
SLATS

(10) 2x4 Wood Slats
AND

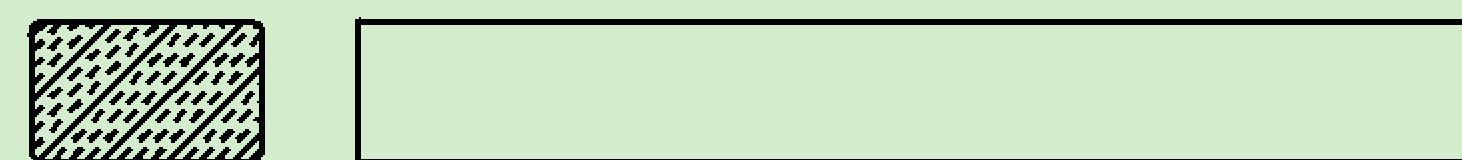

(2) 2x4 Wood Slats
with one rounded edge
OR

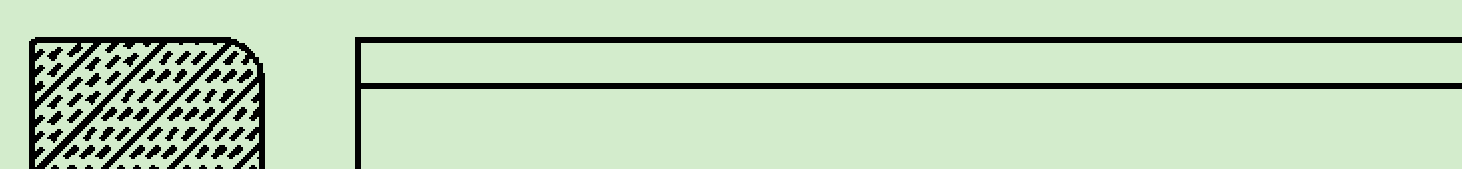



(12) 2nd Site Systems® Slats
(NOT AVAILABLE IN 8' LENGTHS)

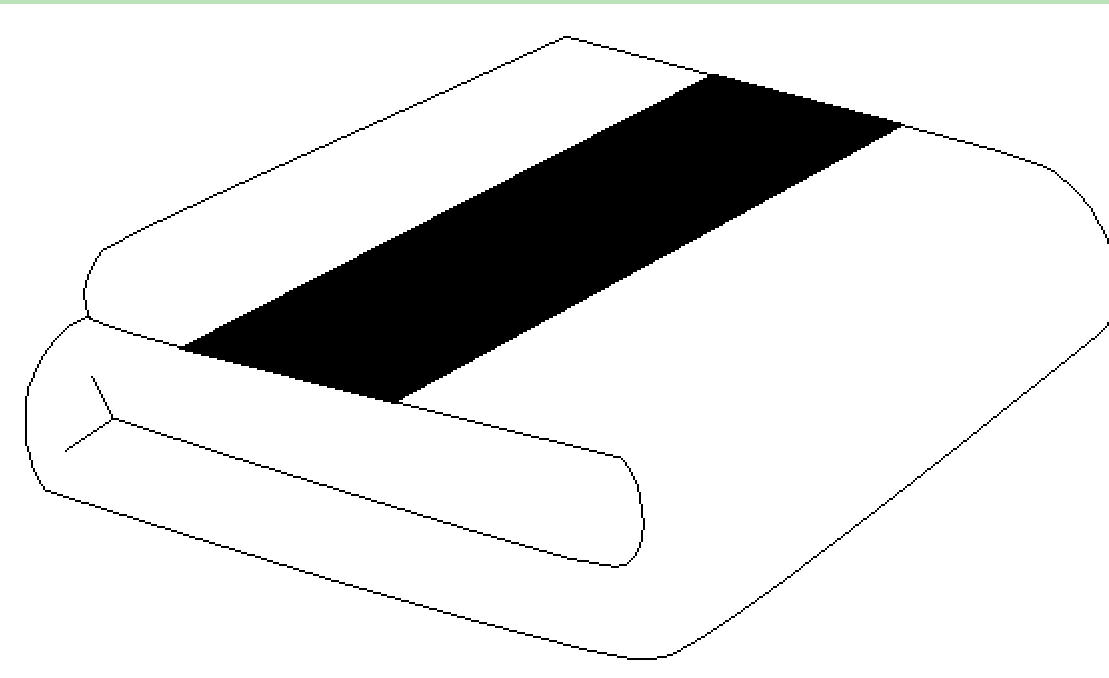

2nd SITE SYSTEMS® SLATS ARE COVERED BY THE
FOLLOWING U.S. PATENTS: 5,660,907; 5,791,047
CANADIAN PATENTS: 1,487,672; 2,184,348 AND
EUROPE, GERMANY, FRANCE, UK, AND NETHERLANDS PATENT: 750543

TOOLS REQUIRED (NOT PROVIDED)

 <p>DRIVER for the provided 5/32-inch HEX DRIVE 5/8-inch or 3/4-inch SOCKETS for use with RATCHET or BREAKER BAR and 5/8-inch or 3/4-inch Wrench for 8' <i>*This symbolizes when to use TOOL to tighten.</i></p>	 <p>TOWELS (or something soft to protect finish)</p>	 <p>HANDS <i>*This symbolizes when to use HAND to tighten.</i></p>
--	---	--

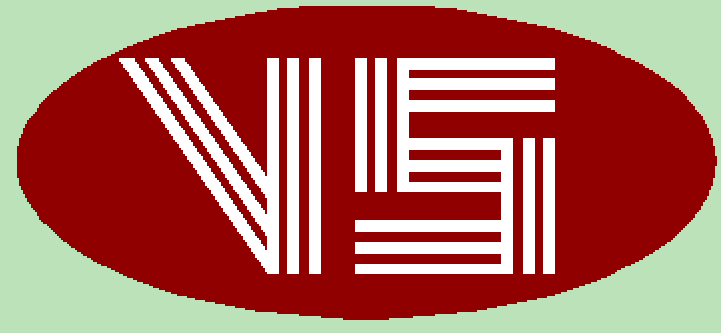

STEP #1 Remove all parts from their boxes and bags, and place on towels or a soft surface to prevent scratching (towels, cardboard, grass, ect.)

STEP #2 Have one person hold up each casting. Have the third person attach the front and back rounded wood slats. Orientate both slats with the rounded edge facing up and towards the outside of the bench as shown. (For 2nd Site Systems® Slats, complete this step with guide holes and metal supports facing down. Keep fastener holes to the inside.)

For step# 2 use lag screw combination (parts A & B) as shown:



**HAND TIGHTEN
 STEPS 2-4**

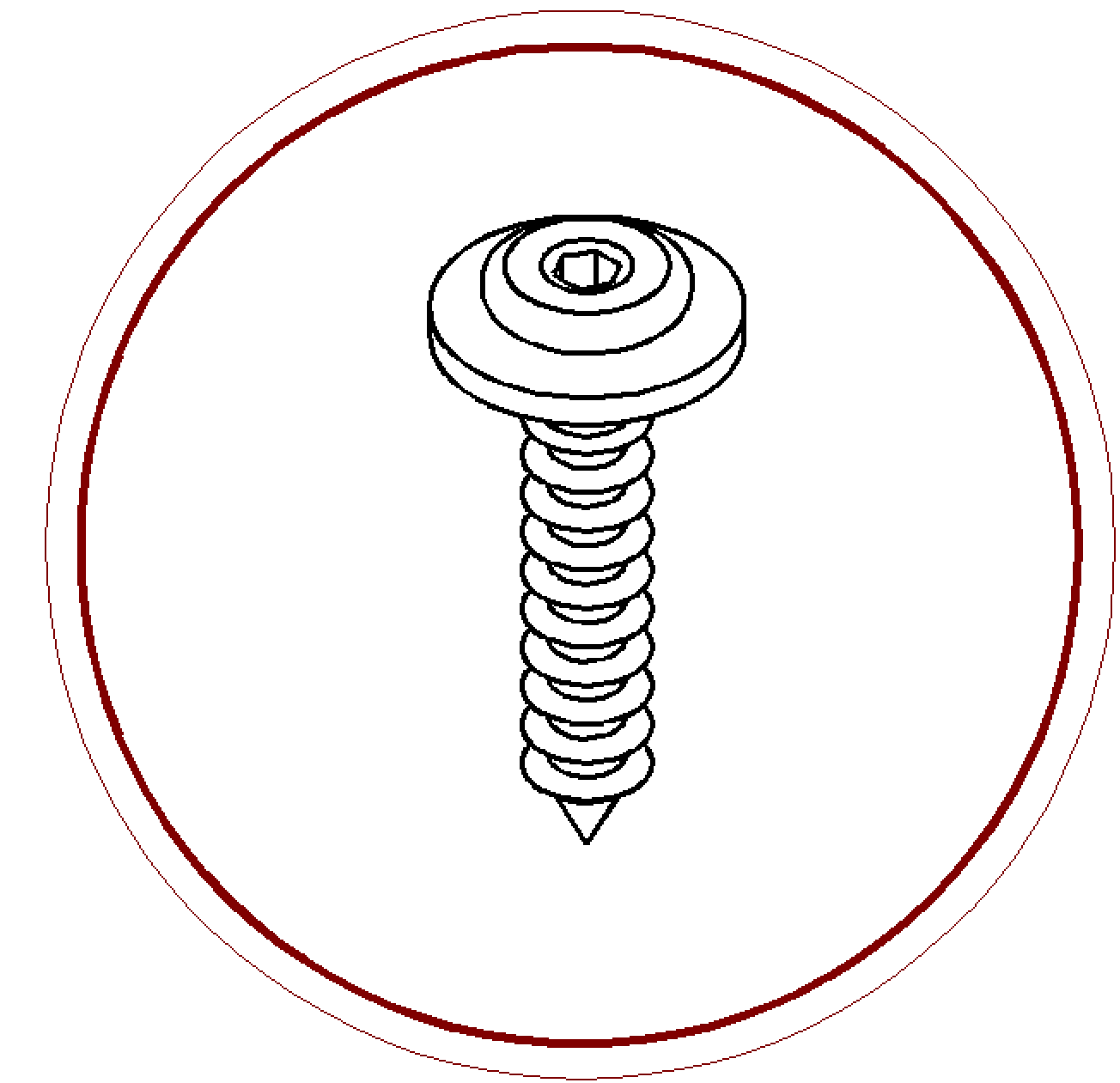
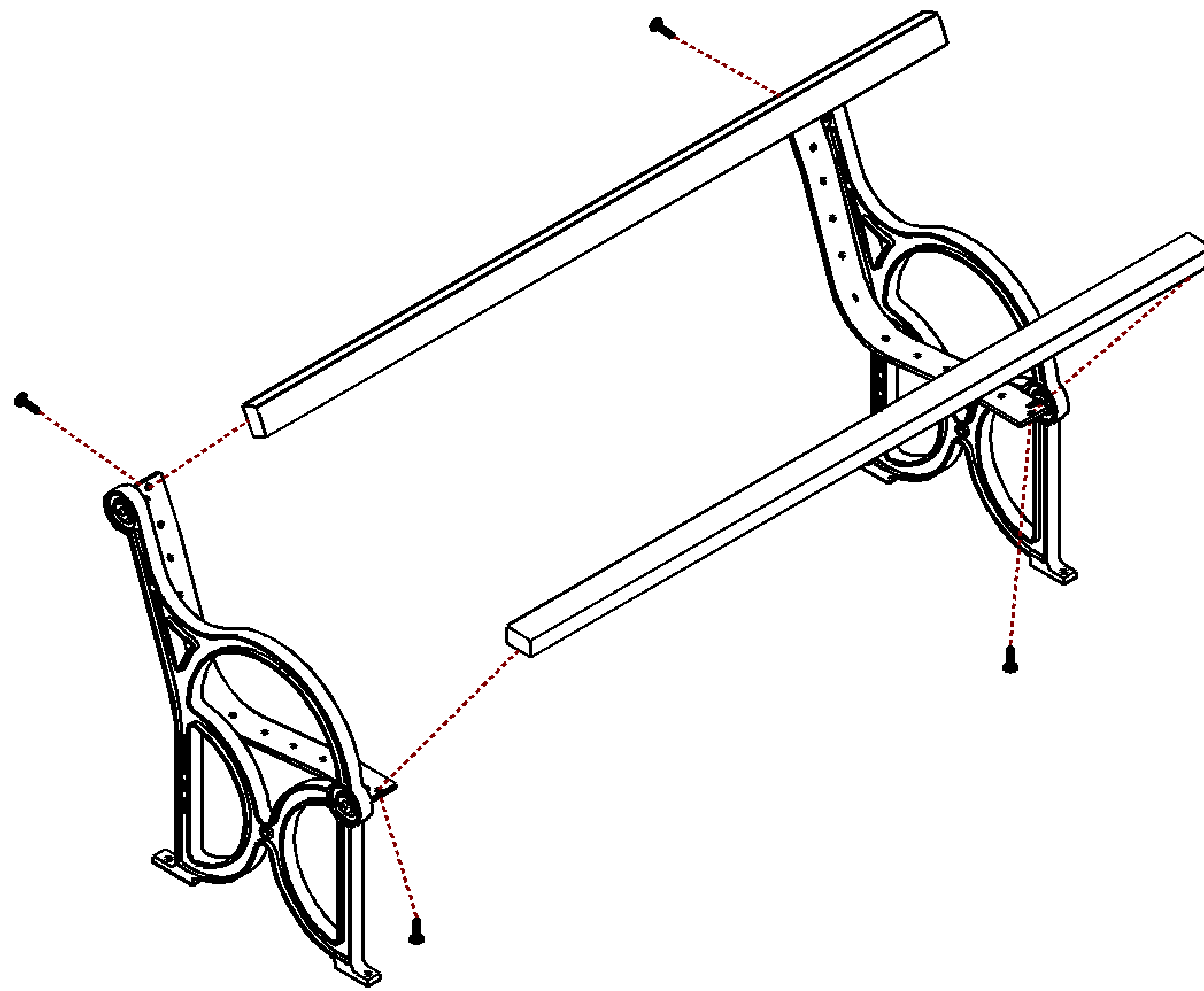

STEP #3 Place the rung between both castings. Attach the rung with bolt configuration (parts D and E) as shown.

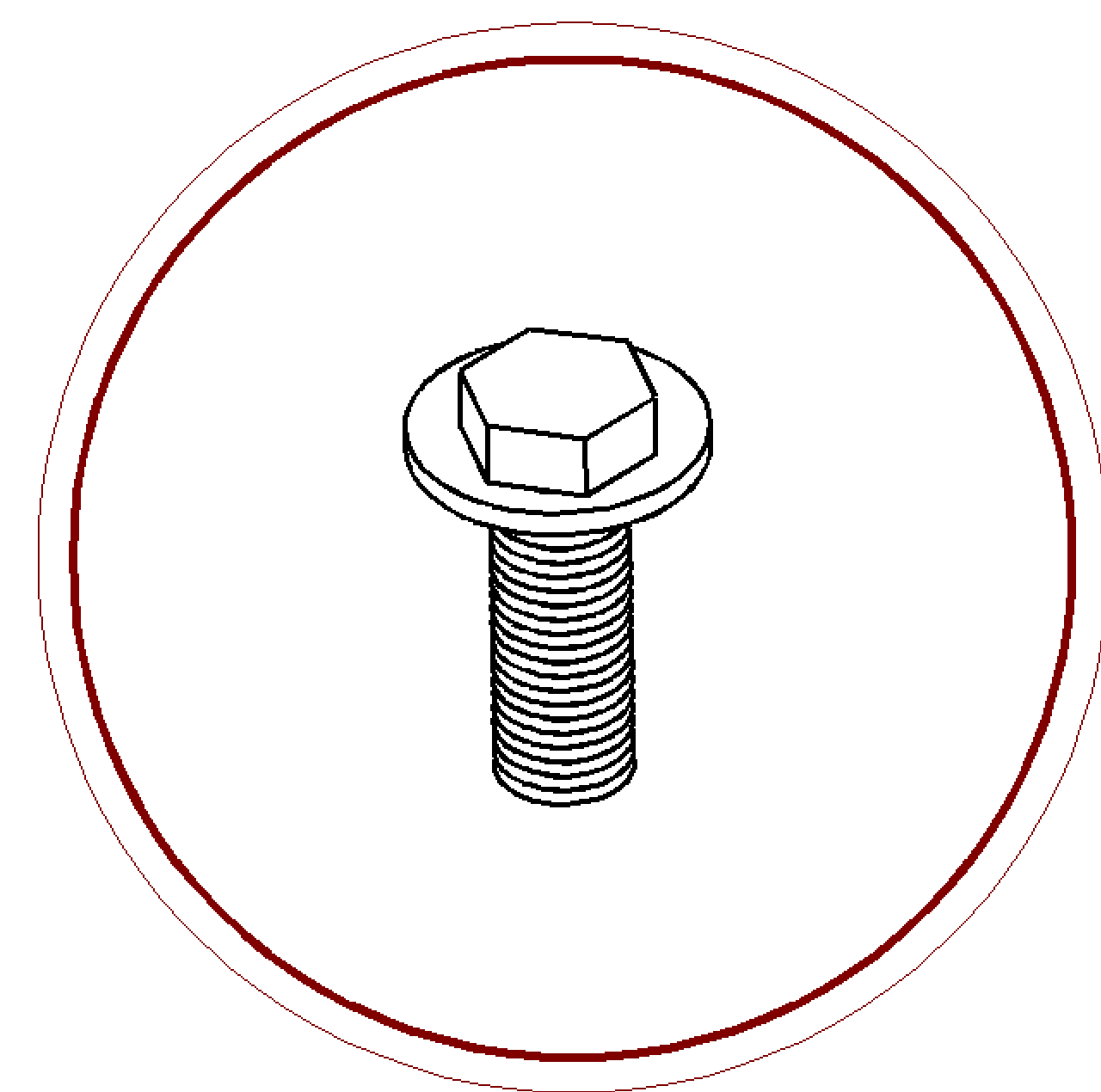
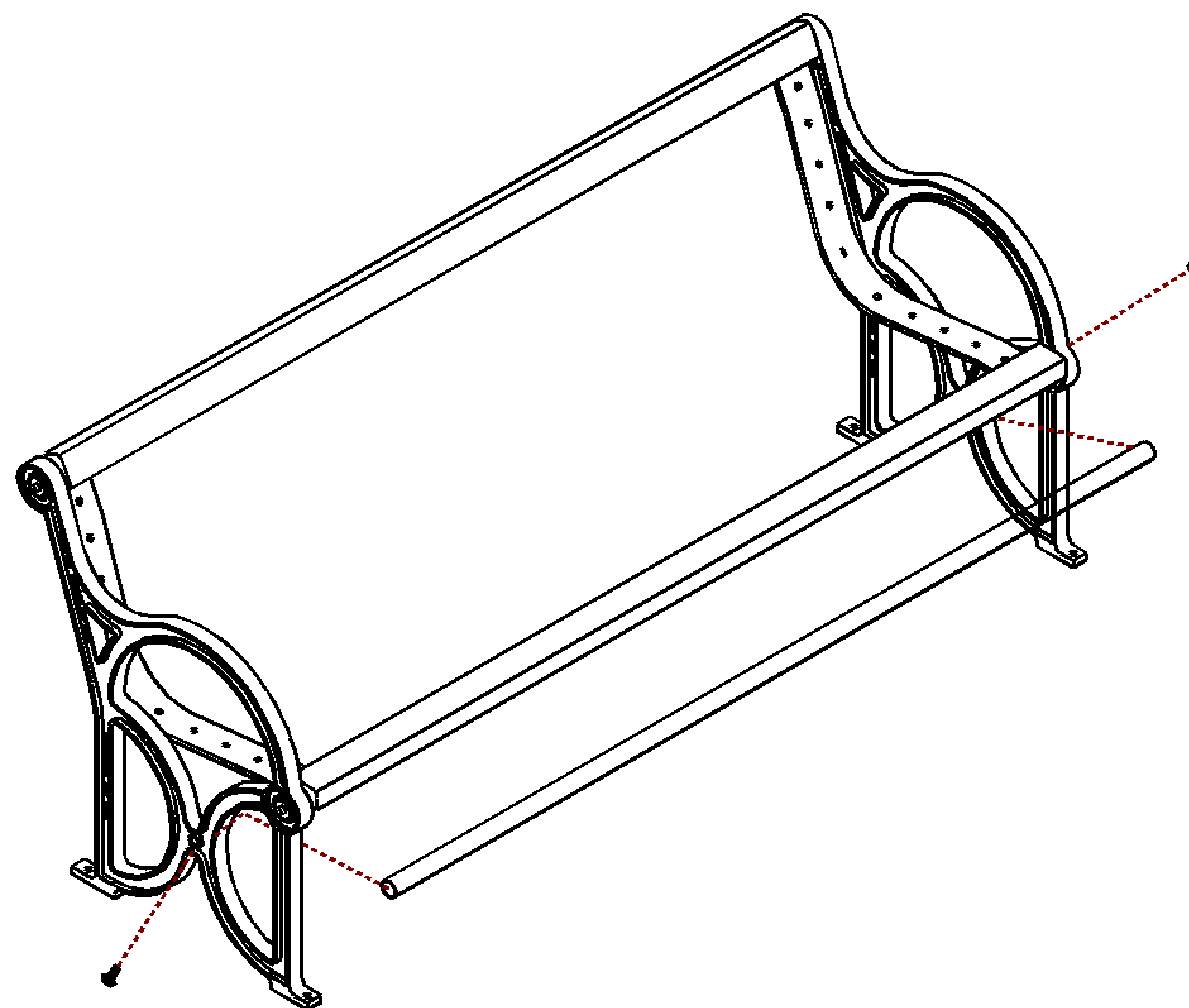

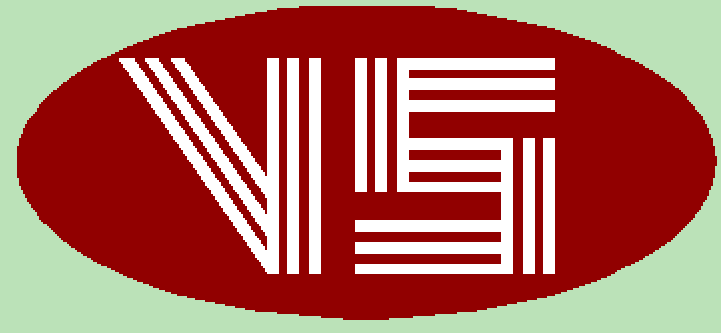

STEP #4

Install all remaining slats using the supplied hardware. Make sure the pre-drilled pilot holes are facing down.



**HAND TIGHTEN
STEPS 4 & 5**

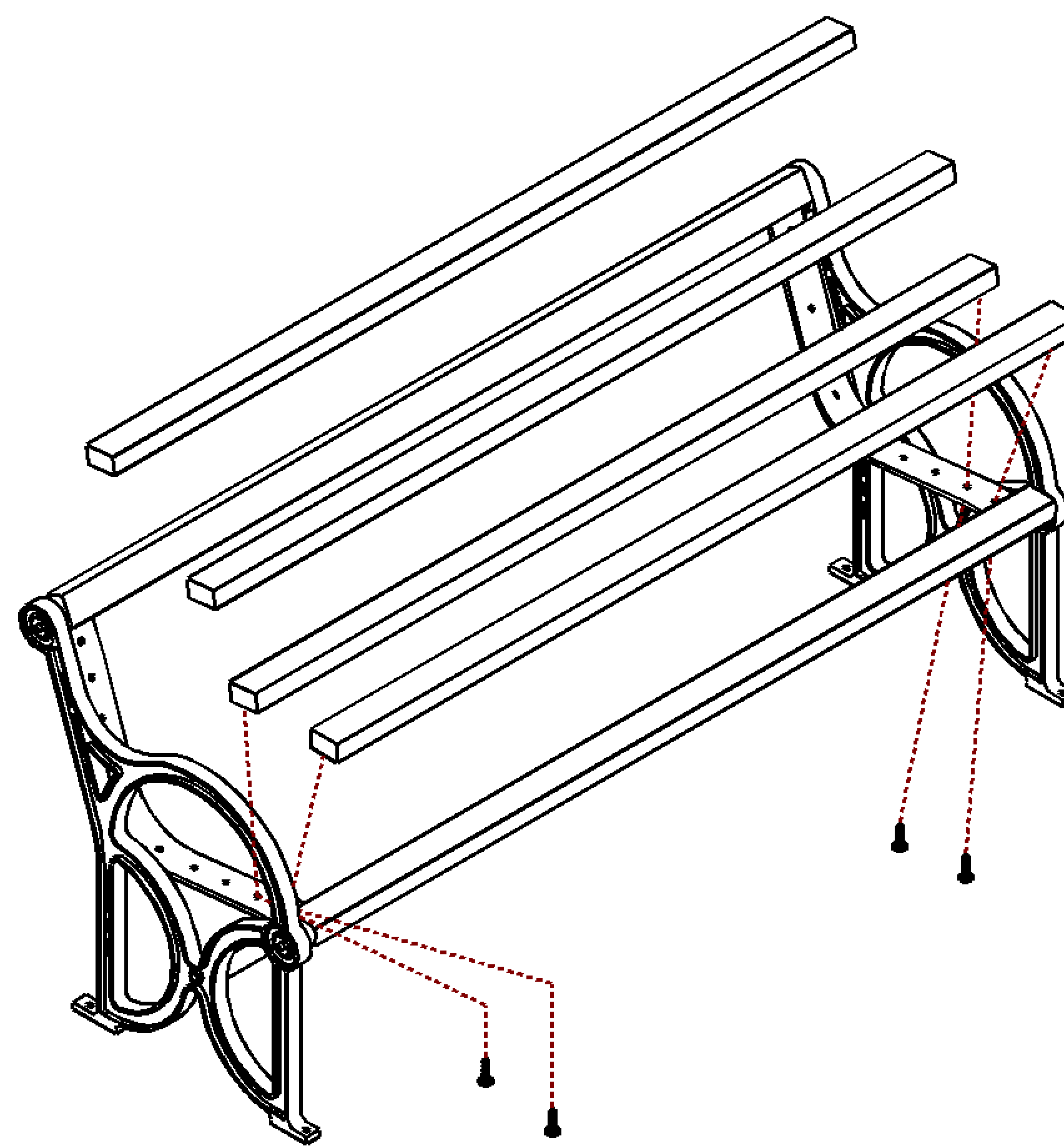
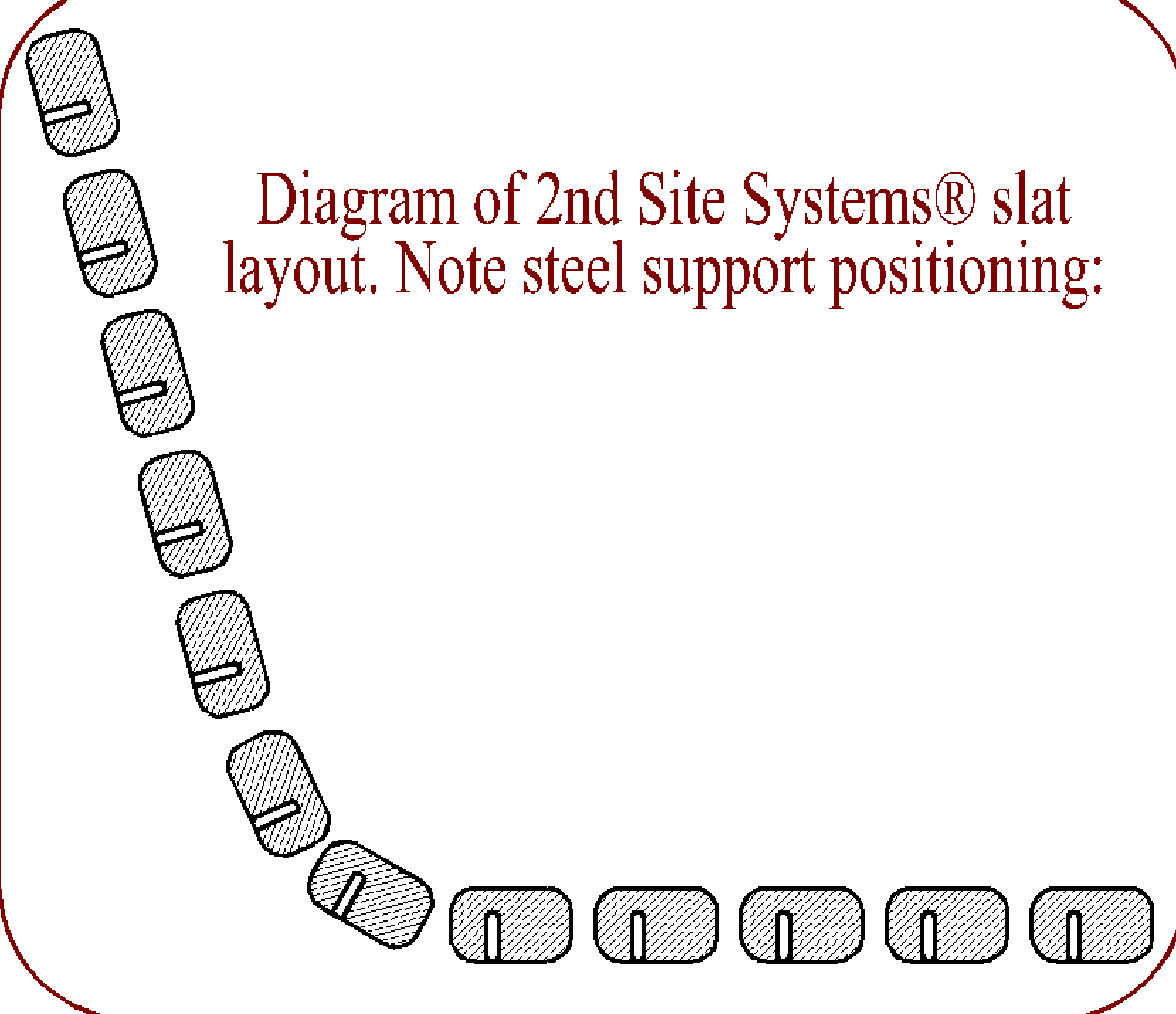

For step 4 and 5 use lag screw combination (parts A & B) as shown:

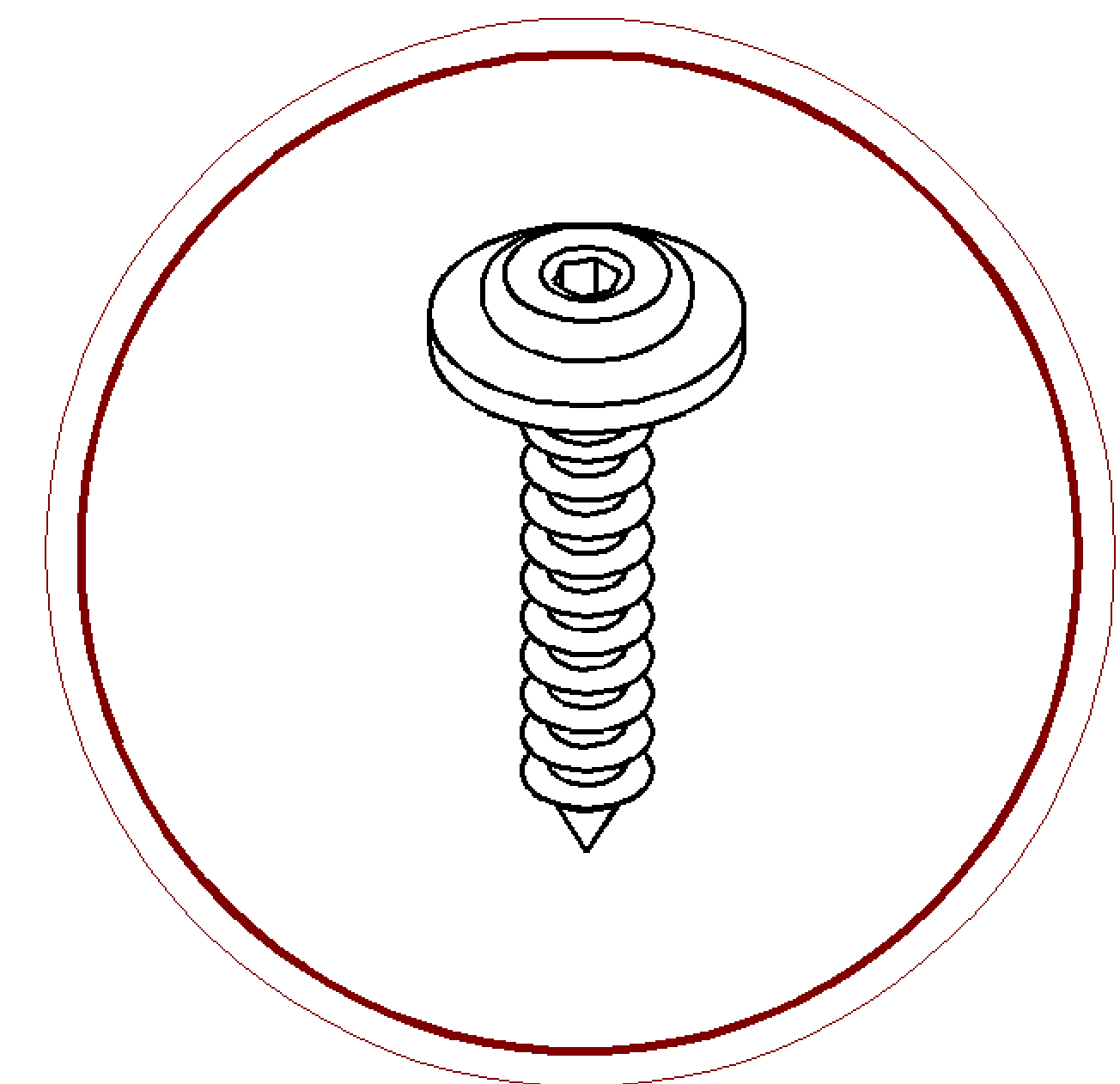

STEP #5

Install center brace using the supplied hardware. For 8', make sure the tab is pointing down.

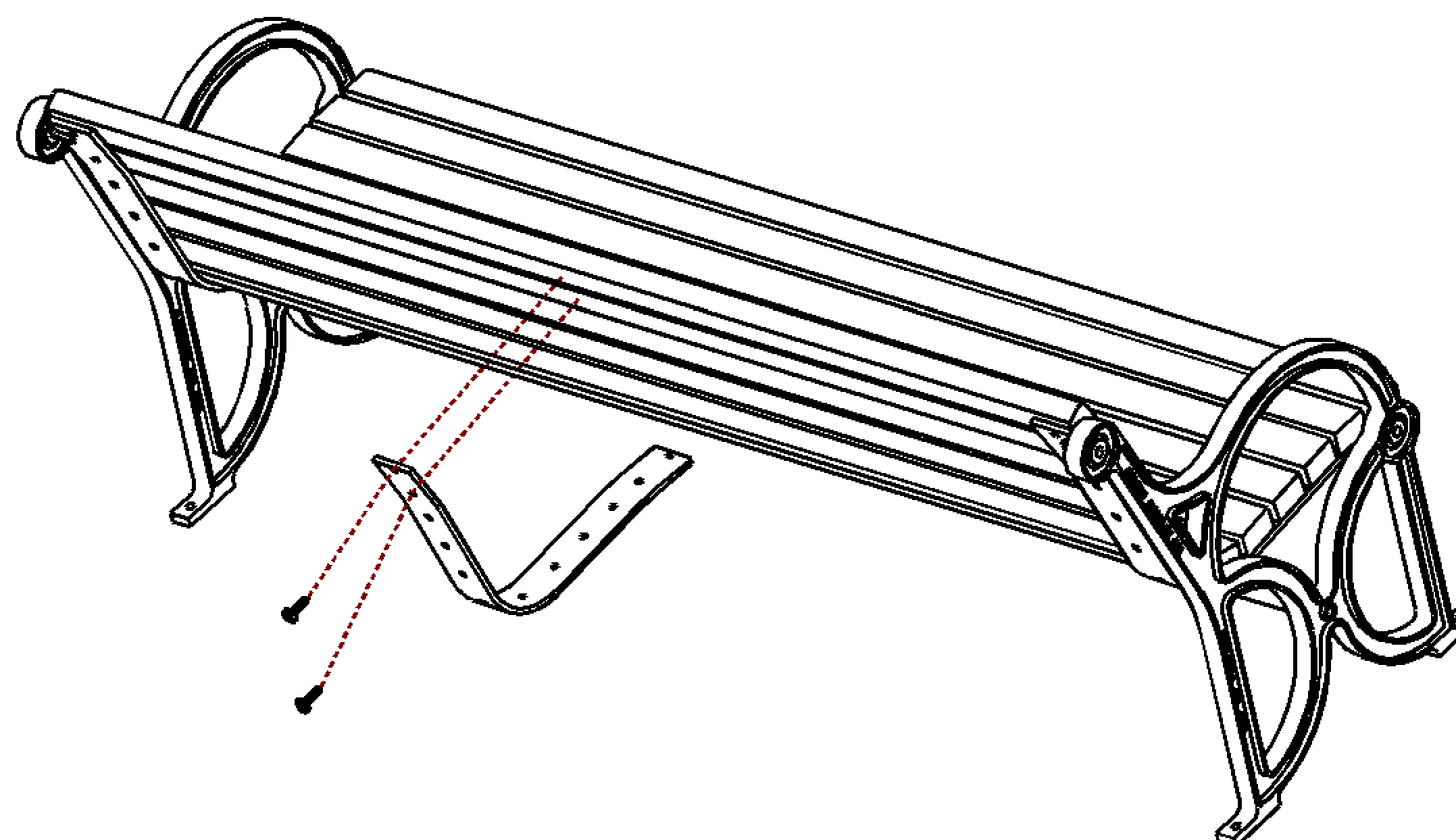

STEP #6

Carefully inspect the bench from front and back to ensure the legs of the bench are standing straight.

STEP #7

Once everything is straight and aligned properly, tighten the first and last slats in an alternating sequence. (First slat Right lag screw, Last slat Left lag screw, etc.)

STEP #8

Carefully reinspect the bench to make sure that all slats are straight and evenly spaced, and tighten the remaining slats in an alternating sequence. After slats are secured, tighten the two bolts on the rung, and then tighten the 10 lag screws on the center brace.

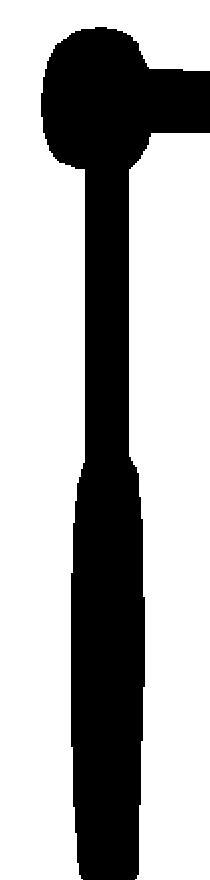

**TOOL TIGHTEN
STEPS 7 & 8**

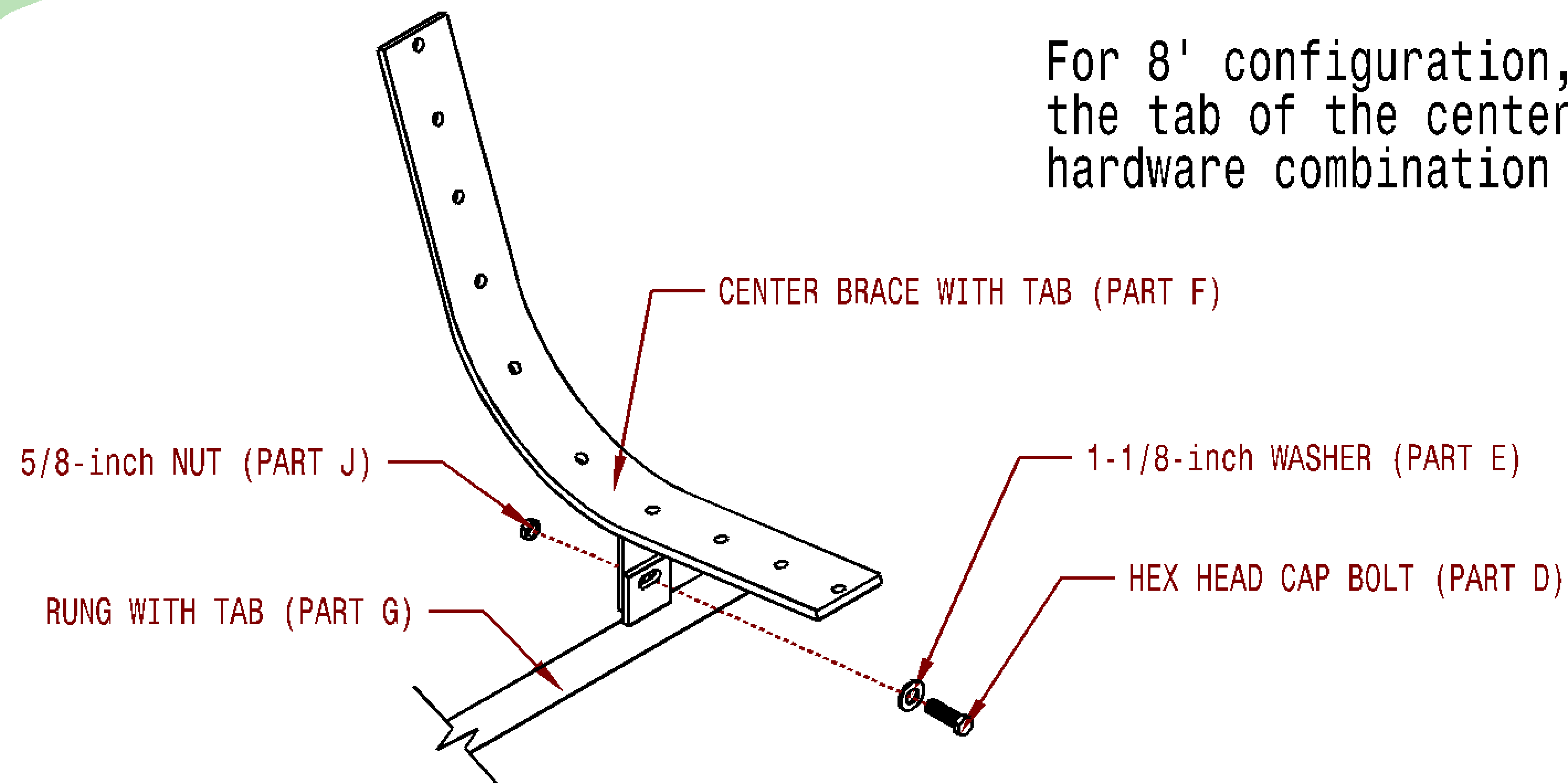
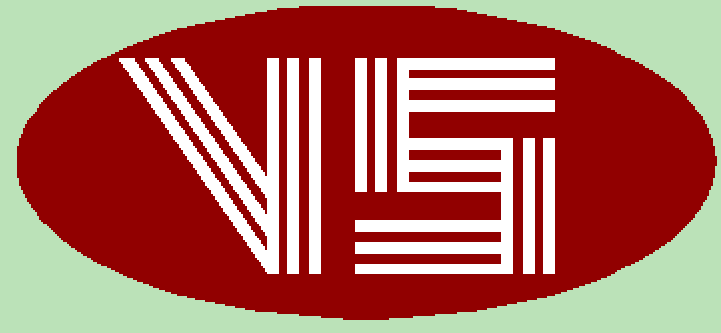

C-18 CITY SITE SERIES™
FINAL PRODUCT

