



# CM-16 Greensites Series™ ASSEMBLY INSTRUCTIONS

Ref# 2009-262, revised 7-24-09 by J.D.R.

READ ALL INSTRUCTIONS THOROUGHLY  
BEFORE YOU BEGIN.

## CHECK ALL PARTS

- Be certain there are no missing parts.
- Be certain all required tools are available.

## REQUIRED TOOLS

- Driver for 5/32-inch Hex Drive.
- Ratchet or Breaker Bar.
- Socket 1/4
- 5/16" Allen Wrench

## ASSISTANCE REQUIRED

- 2 people recommended to assemble product.
- Necessary to handle, fit, and secure components.
- Heavy lifting.

All specifications are subject to change. Contact manufacturer for details.  
Directions do not include center armrest attachment

## DELIVERY, STORAGE, and HANDLING

- Delivery:** Deliver products to site in manufacturer's original, unopened containers and packaging. Upon delivery, examine packages immediately to ensure all products are complete and undamaged.
- Storage:** Store products in a protected, dry area in manufacturer's unopened containers and packaging
- Handling:** Protect product's finish from damage during handling and installation.

## INSTALLATION

- Clearance** for 1/2-inch (9.53mm) anchor bolts (anchor bolts not provided by Victor Stanley, Inc.)
- Mounting:** It is not recommended to locate anchor bolts until bench is in place. This Victor Stanley, Inc. product must be permanently affixed to the ground. Consult your local codes for regulations.

## PROTECTION

- Protect** products prior to installation by having the remain in The manufacturer's packaging and container.

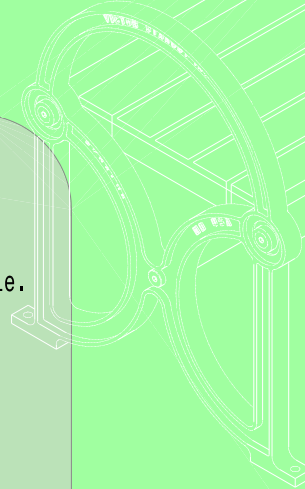





Should you have any problems, please contact Victor Stanley, Inc.

[www.victorstanley.com](http://www.victorstanley.com)

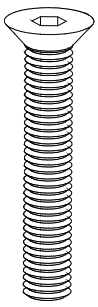
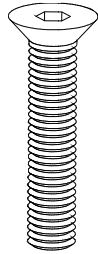
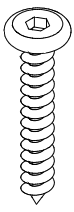
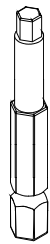

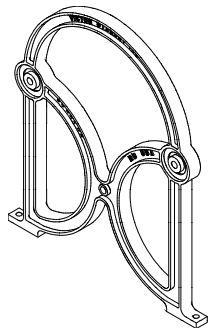
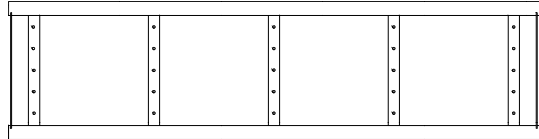
## PARTS LIST

<p><b>Ax4</b> 3" TAPERED HEAD BOLT</p> 	<p><b>Bx2</b> 2-1/2" TAPERED HEAD BOLT</p> 	<p><b>Cx25</b> LAG SCREW</p> 	<p><b>Dx1</b> 5/32-inch HEX DRIVE BIT</p> 	<p><b>Ex25</b> WASHER</p> 
<p><b>Gx5</b> PRE-DRILLED SEAT SLAT</p> 				
<p><b>Fx2</b> CASTING</p> 		<p><b>Hx1</b> SEAT SUPPORT TRUSS</p> 		
		<p><b>Ix1</b> SEAT RUNG</p> 		

## TOOLS REQUIRED (NOT PROVIDED)

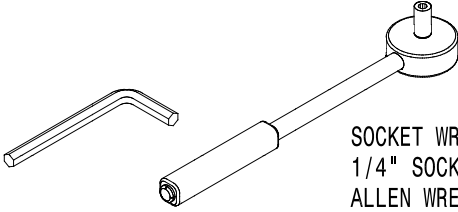

SOCKET WRENCH WITH  
1/4" SOCKET & 5/16"  
ALLEN WRENCH



HAND

\*This symbolizes when to use HAND to tighten.



**STEP #1** Remove all parts from their boxes and bags, and place on towels or a soft surface to prevent scratching the finish (towels, cardboard, grass, ect.)

**STEP #2** INSERT BOLT (PART A ) THROUGH CASTING AND INTO THE SEAT SUPPORT TRUSS (AS SHOWN) HAND TIGHTEN.

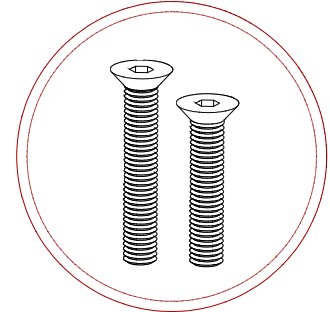

For step# 2 & 3  
use bolts A & B  
(as shown)

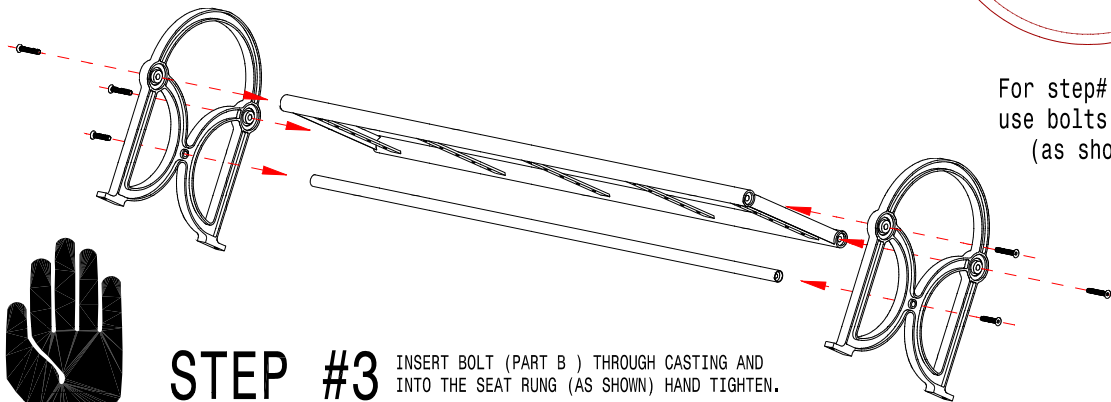

HAND TIGHTEN

**STEP #3** INSERT BOLT (PART B ) THROUGH CASTING AND INTO THE SEAT RUNG (AS SHOWN) HAND TIGHTEN.

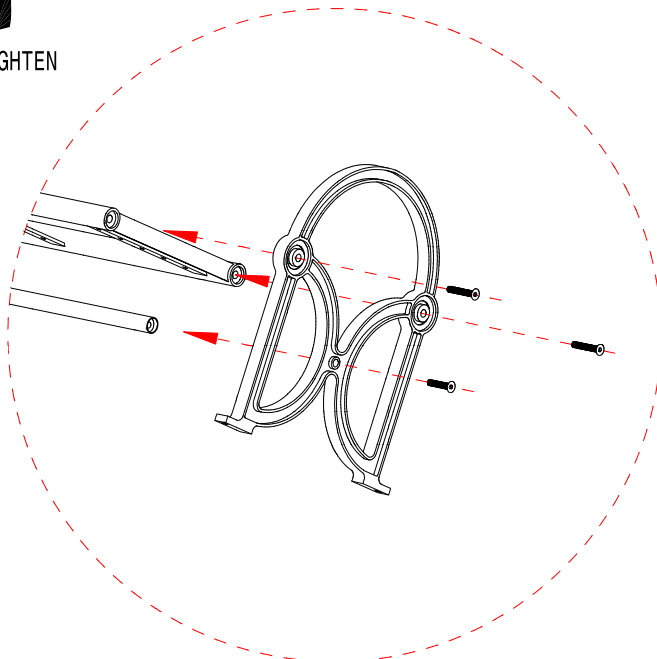

**!** MAKE SURE THE SEAT SUPPORTS ARE POSITIONED AT THE BOTTOM OF THE TRUSS WHEN ATTACHING TO CASTINGS (AS SHOWN BELOW)

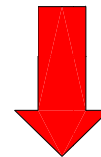



## STEP #4

INSERT LAG SCREW AND WASHER COMBINATION (PART C,E ) THROUGH SEAT SUPPORT TRUSS FROM BELOW (AS SHOWN) HAND TIGHTEN LAG SCREWS INTO THE PREDRILLED HOLES OF THE SEAT BOARDS. DO NOT TIGHTEN FULLY UNTIL ALL SCREWS ARE INSERTED AND THE BOARDS ARE EVENLY SPACED

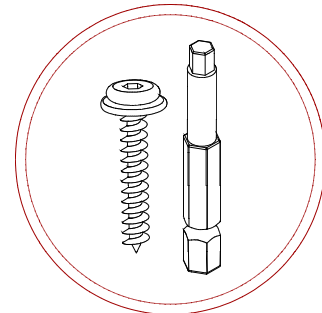
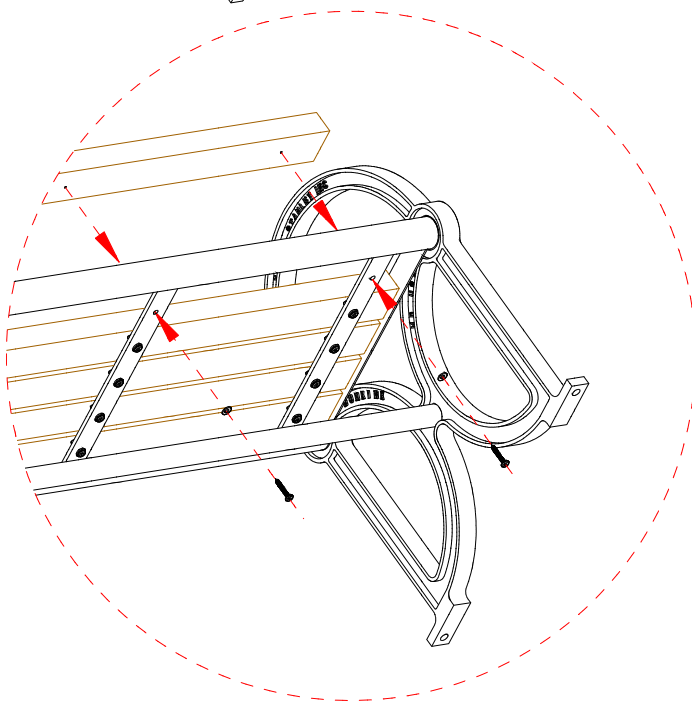
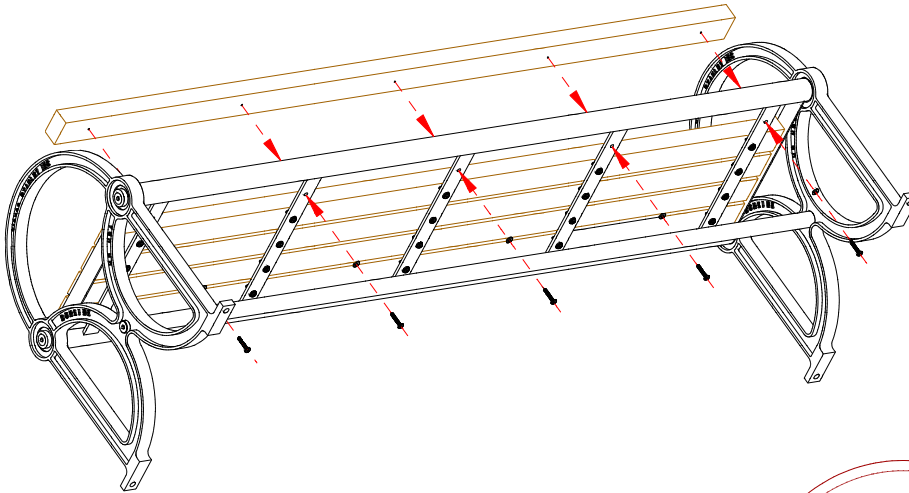

For step# 4  
use lag screw and  
washer combination C/E  
(as shown)

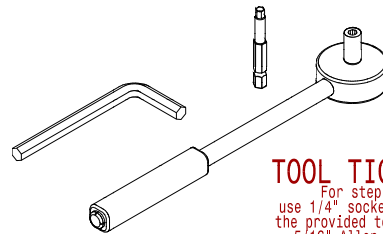

**TOOL TIGHTEN**  
For step #5  
use 1/4" socket wrench  
the provided tool and a  
5/16" Allen wrench

## STEP #5

TOOL TIGHTEN ALL BOLTS

\*It is recommended to apply dish soap as a lubricant to the lag screws (part A) before attaching seat slats to frame



**VICTOR STANLEY, INC.®**  
-Manufacturers of Quality Site Furnishings since 1962-

CM-16 Greensites Series™  
ASSEMBLY INSTRUCTIONS

PAGE 5 of 5

## CM-16 Greensites Series™ FINAL PRODUCT

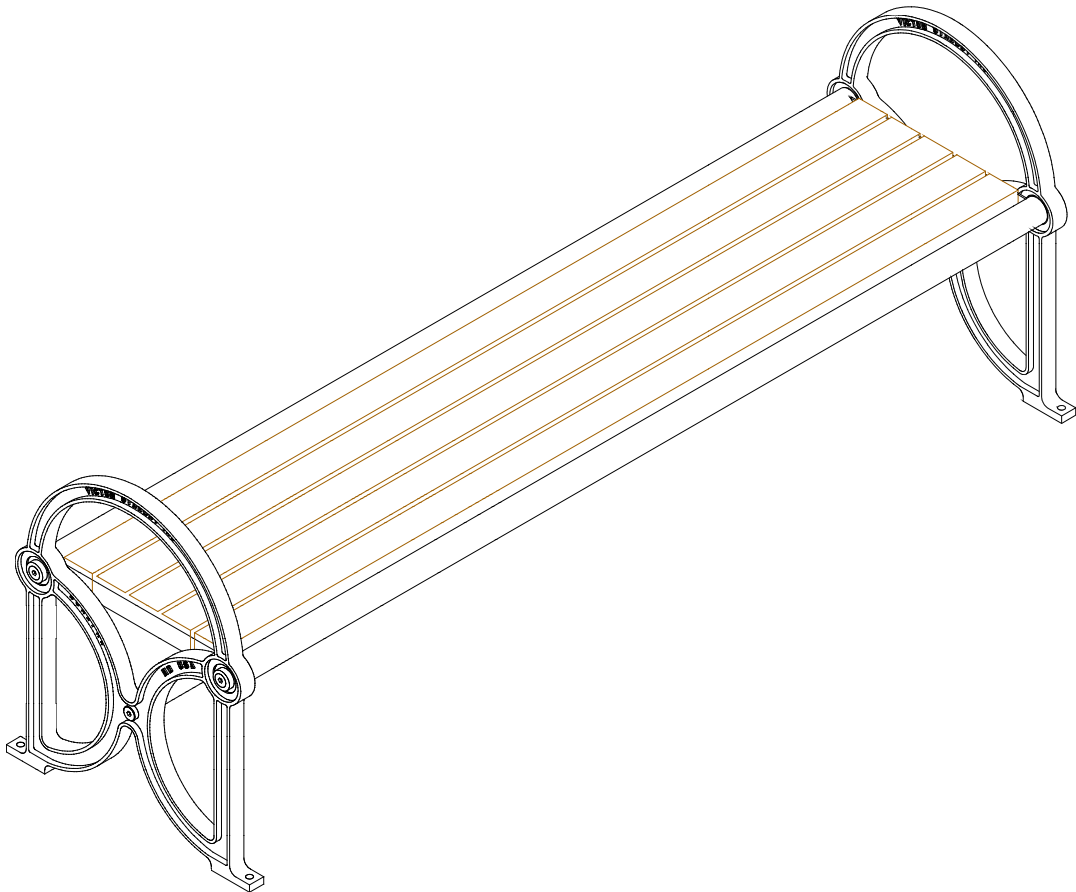

*Thank you for choosing Victor Stanley, Inc.*