



# CM-138 GREENSITES SERIES™ ASSEMBLY INSTRUCTIONS

Ref# 2009-169, revised 5-28-09 by J.D.R.

READ ALL INSTRUCTIONS THOROUGHLY  
BEFORE YOU BEGIN.

## CHECK ALL PARTS

- Be certain there are no missing parts.
- Be certain all required tools are available.

## REQUIRED TOOLS

- Driver for 5/32-inch Hex Drive.
- Ratchet or Breaker Bar.
- Socket 1/4 & 1/2-inch
- Standard 1/2 & 3/4-inch wrench
- 3/16-inch Allen Wrench

## ASSISTANCE REQUIRED

- 3 people recommended to assemble product.
- Necessary to handle, fit, and secure components.
- Heavy lifting.



All specifications are subject to change. Contact manufacturer for details.  
Directions do not include center armrest attachment

## DELIVERY, STORAGE, and HANDLING

- Delivery: Deliver products to site in manufacturer's original, unopened containers and packaging. Upon delivery, examine packages immediately to ensure all products are complete and undamaged.
- Storage: Store products in a protected, dry area in manufacturer's unopened containers and packaging
- Handling: Protect product's finish from damage during handling and installation.

## INSTALLATION

- Clearance for 1/2-inch (9.53mm) anchor bolts (anchor bolts not provided by Victor Stanley, Inc.)
- Mounting: It is not recommended to locate anchor bolts until bench is in place. This Victor Stanley, Inc. product must be permanently affixed to the ground. Consult your local codes for regulations.

## PROTECTION

- Protect products prior to installation by having the remain in The manufacturer's packaging and container.









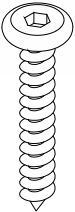

Should you have any problems, please contact Victor Stanley, Inc.

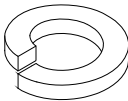
[www.victorstanley.com](http://www.victorstanley.com)

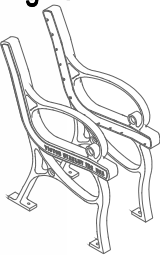

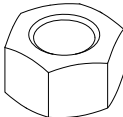
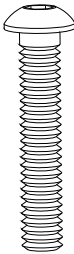
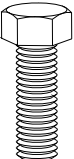
## PARTS LIST

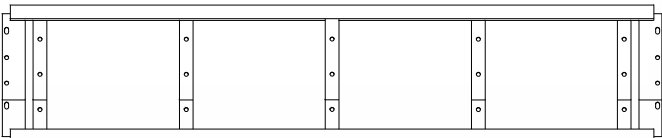
<p><b>Ax30</b></p> <p>7mm x 40mm LAG SCREW</p> 	<p><b>Bx1</b></p> <p>5/32-inch HEX DRIVE BIT</p> 	<p><b>Cx16</b></p> <p>LOCK WASHER</p> 	<p><b>Dx30</b></p> <p>WASHER</p> 	
<p><b>Jx2</b></p> <p>LEG SECTION 1 Left 1 Right</p> 	<p><b>Ex32</b></p> <p>SMALL WASHER</p> 	<p><b>Fx2</b></p> <p>LARGE WASHER</p> 	<p><b>Gx16</b></p> <p>HEX NUT</p> 	<p><b>Hx16</b></p> <p>1-2" BOLT</p> 
	<p><b>Ix2</b></p> <p>RUNG BOLT</p> 	<p><b>Kx1</b></p> <p>RUNG</p> 		
	<p><b>Lx6</b> (PRE-DRILLED) SEAT SLAT</p> 			
<p><b>Mx2</b></p> <p>SEAT AND BACK FRAME</p>				

## TOOLS REQUIRED (NOT PROVIDED)

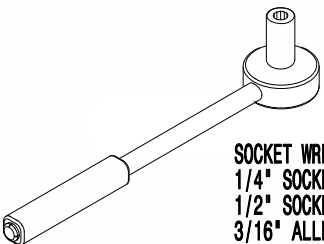

SOCKET WRENCH  
1/4" SOCKET  
1/2" SOCKET  
3/16" ALLEN WRENCH

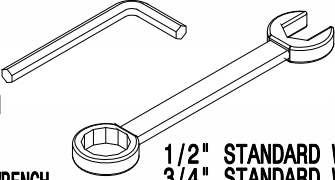

1/2" STANDARD WRENCH  
3/4" STANDARD WRENCH



HANDS

*\*This symbolizes when to use HAND to tighten.*



### STEP #1

Remove all parts from their boxes and bags, and place on towels or a soft surface to prevent scratching the finish (towels, cardboard, grass, ect.)

### STEP #2

With help, place trusses and rung (parts M & K) into place as shown and line up holes. Make sure that the "bend" in the seat and back trusses are as shown.



**HAND TIGHTEN  
STEPS 2 & 3**

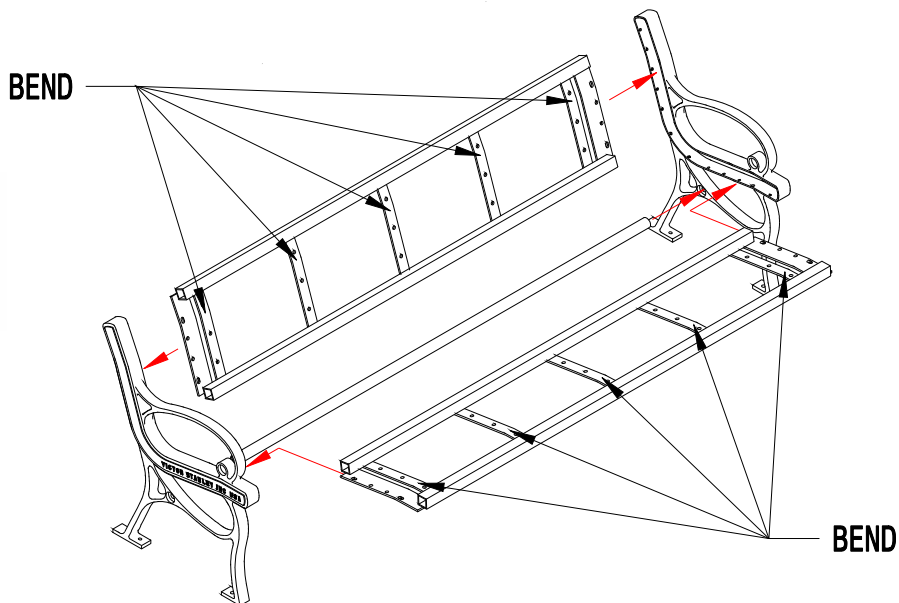

### STEP #3

Insert bolts (part H ) from back through holes (as shown). Insert seat rung (part K ) into casting and tighten bolts (part I ) as shown. Hand tighten all bolts.

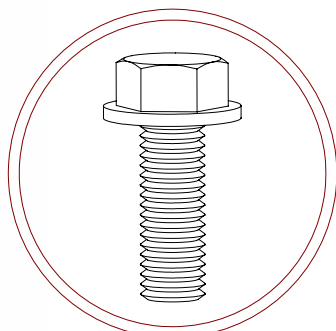

To attach bottom rung use bolt and fastener combination I/F (as shown)

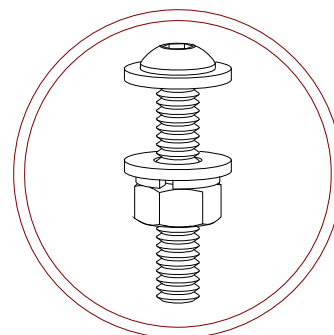
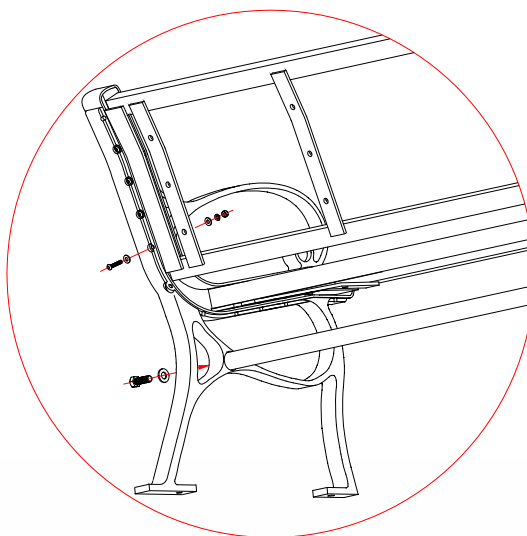

To attach back truss use bolt and fastener combination H/E/E/C/G (as shown)



# STEP #4

It is recommended to insert bolts on one side of bench and hand tighten, then repeat steps 2 & 3 on the opposite side, securing one bolt and swinging the casting into place. Once all bolts are inserted tool tighten all bolts.  
**DO NOT OVER TIGHTEN**

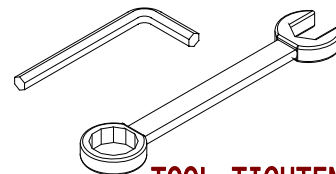
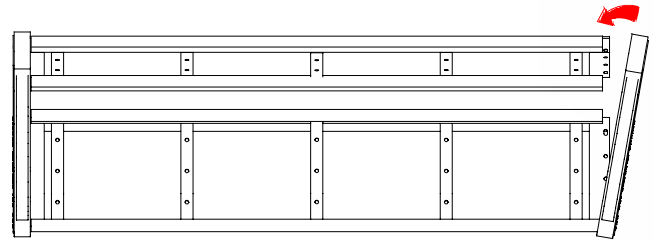
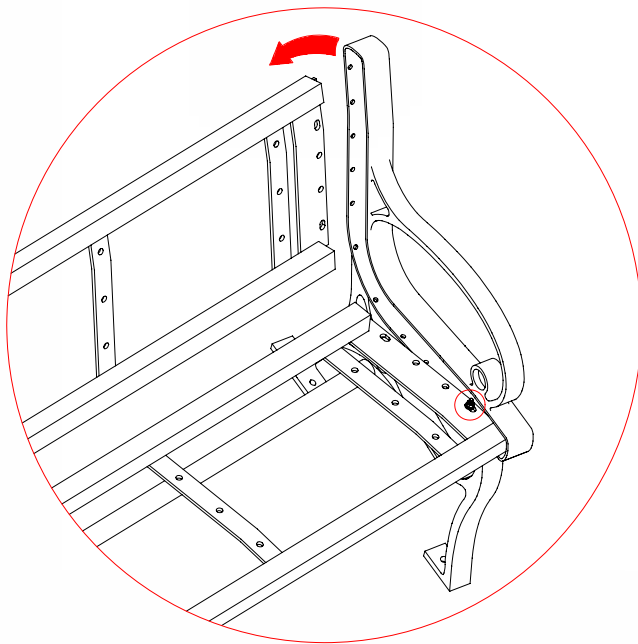

### TOOL TIGHTEN

use 3/16" allen wrench  
 1/2" standard wrench  
 3/4" standard wrench

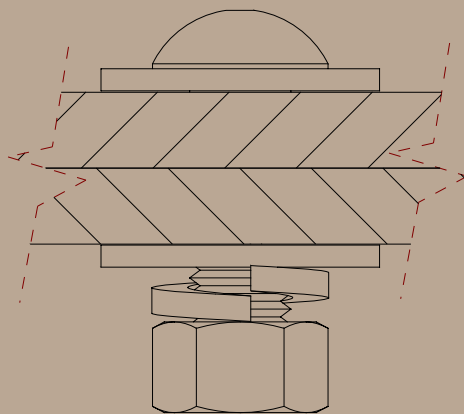

**Bolt & fastener before  
 tool tightening**

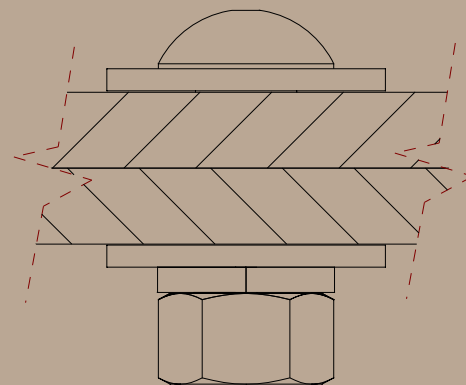

**Bolt & fastener after  
 tool tightening**



**STEP #5** Place (1) board on seat section and insert screws (from bottom/back) through support truss (as shown) into pre-dilled holes, secure screws using tool provided. **DO NOT** tighten fully until all screws and boards are in place.

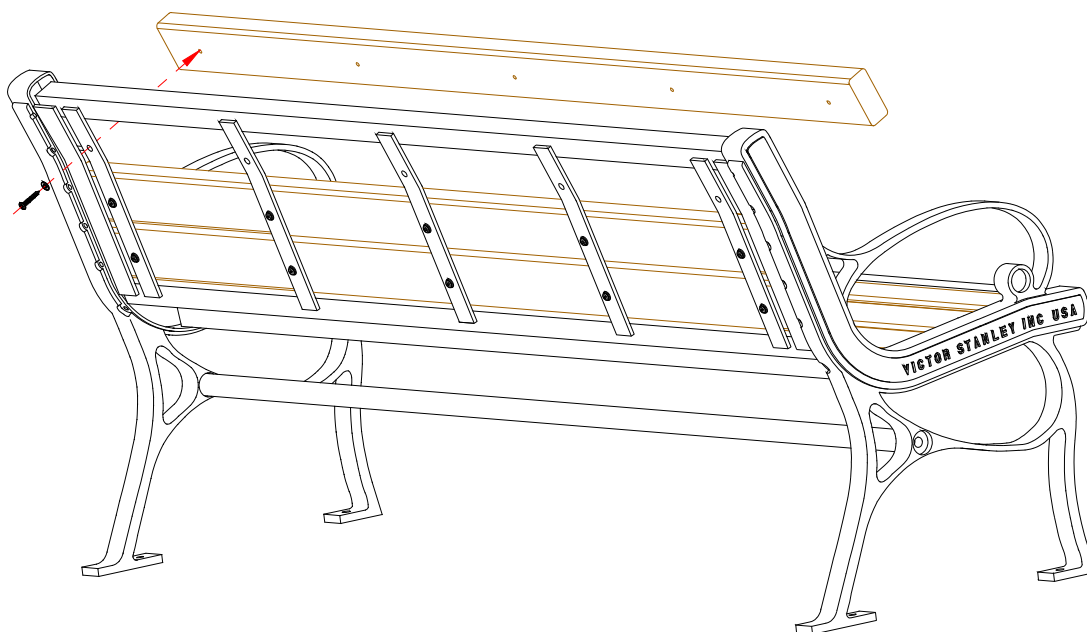

**STEP #6** Repeat step five until all boards are attached and properly spaced. Use tool provided and tool tighten all screws. **DO NOT OVER TIGHTEN.**

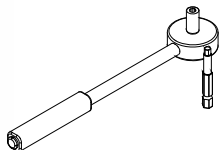

**TOOL TIGHTEN**  
use tool provided  
and 1/4" socket wrench

\*It is recommended to apply dish soap as a lubricant to the lag screws (part A) before attaching seat slats to frame

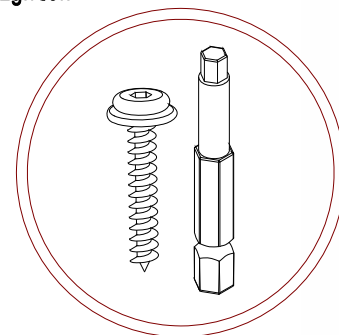

For step# 5 & 6  
use lag screw and washer  
combination A/D (as shown)



**VICTOR STANLEY, INC.®**  
-Manufacturers of Quality Site Furnishings since 1962-

**CM-138 GREENSITES SERIES™**  
**ASSEMBLY INSTRUCTIONS**

PAGE 6 of 6

## CM-138 GREENSITES SERIES™ FINAL PRODUCT

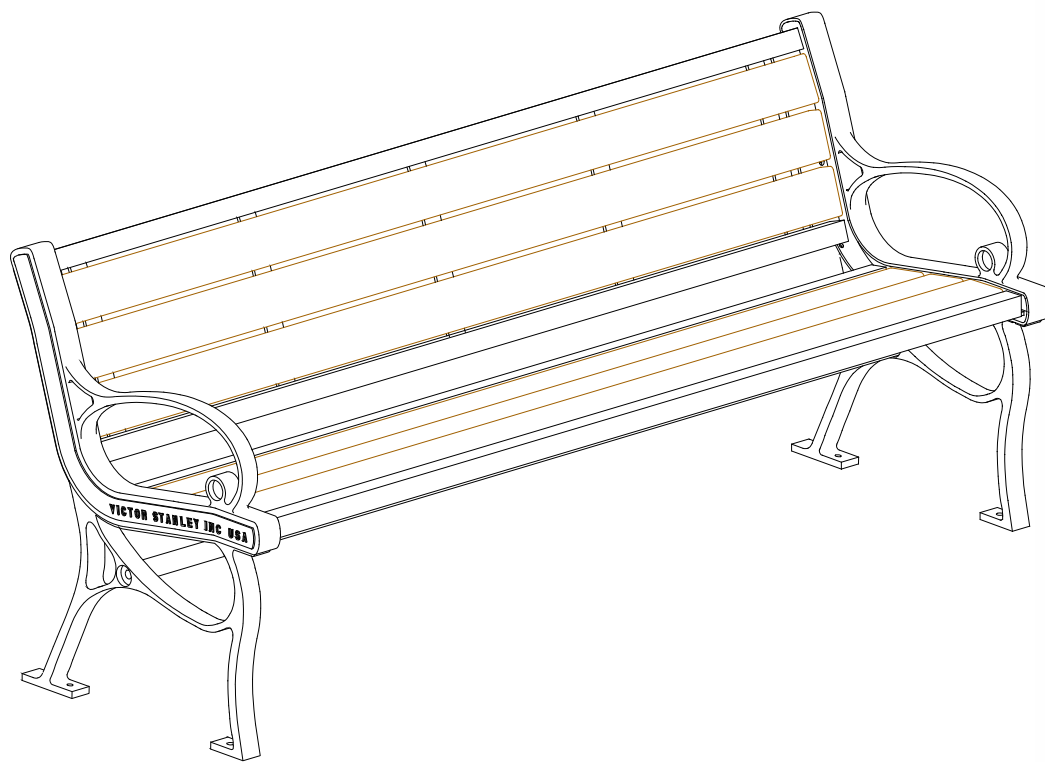

*Thank you for choosing Victor Stanley, Inc.*