

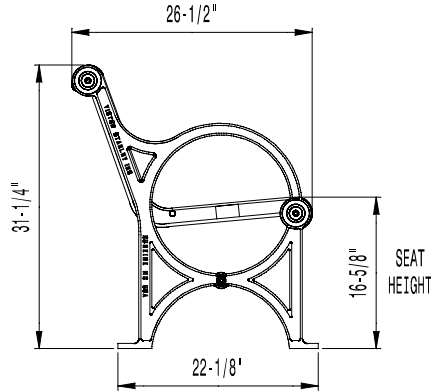

**VICTOR STANLEY, INC.®**  
*-Manufacturers of Quality Site Furnishings since 1962-*

P.O. DRAWER 330 - DUNKIRK, MD 20754 USA  
 TOLL FREE: (800) 368-2573 (USA & CANADA)  
 TEL (301) 855-8300 - FAX (410) 257-7579  
 WEB SITE: HTTP://WWW.VICTORSTANLEY.COM

\* ALL DIMENSIONS ARE IN INCHES \*



SCROLLED VERTICAL STEEL  
 SLATS ARE FORMED FROM SECTIONS  
 OF 1/4" x 1-1/2" SOLID STEEL BARS

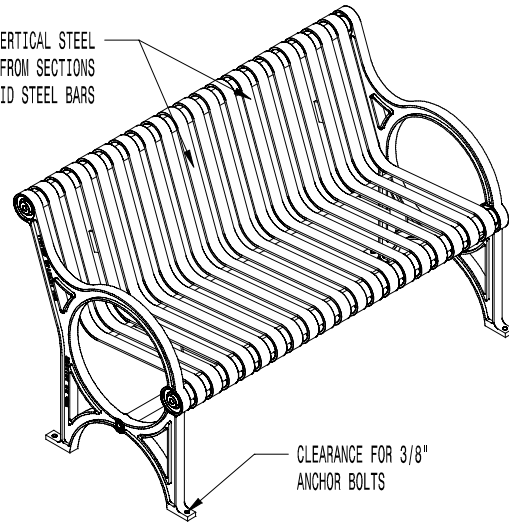

CLEARANCE FOR 3/8"  
 ANCHOR BOLTS

INTEGRAL WELDED CROSS-MEMBERS  
 OF 1-7/8" TUBULAR STEEL

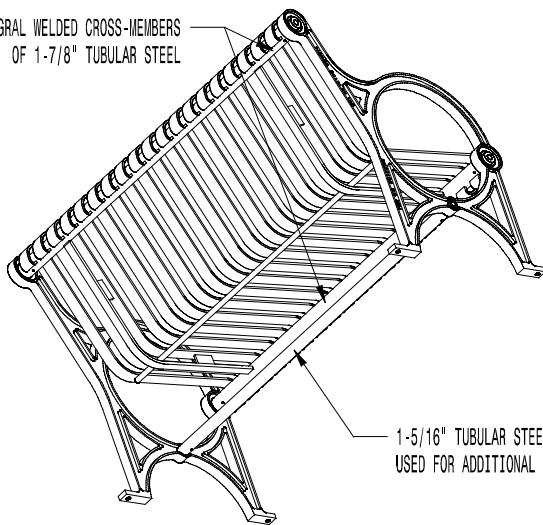

1-5/16" TUBULAR STEEL RUNG  
 USED FOR ADDITIONAL SUPPORT

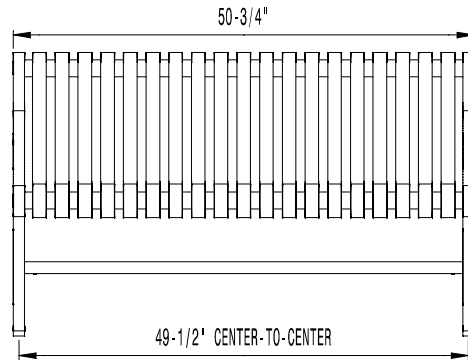

CENTER-TO-CENTER DISTANCES ARE APPROXIMATE  
 (VARIATIONS IN CASTINGS ARISE FROM DIFFERENT RATES OF COOLING)

AVAILABLE OPTIONS:

POWDER COATING

10 STANDARD COLORS, 2 OPTIONAL METALLIC COLORS,  
 CUSTOM COLORS (INCLUDING THE RAL RANGE)

CUSTOM PLAQUES

ENGRAVED CAST BRONZE PLAQUES

INTERMEDIATE & CENTER ARMRESTS

4', 6', & 8' AVAILABLE WITH OPTIONAL ARMRESTS

LENGTHS

STANDARD 4' LENGTH SHOWN

STANDARD 6'

STANDARD 8'

NOTES:

1. DUCTILE IRON CASTINGS COME WITH A TEN YEAR WARRANTY AGAINST BREAKAGE.
2. DRAWINGS NOT TO SCALE. DO NOT SCALE DRAWINGS.
3. ALL FABRICATED METAL COMPONENTS ARE STEEL SHOTBLASTED, ETCHED, PHOSPHATIZED, PREHEATED, AND ELECTROSTATICALLY POWDER-COATED WITH T.G.I.C. POLYESTER POWDER COATINGS. PRODUCTS ARE FULLY CLEANED AND PRETREATED, PREHEATED AND COATED WHILE HOT TO FILL CREVICES AND BUILD COATING FILM. COATED PARTS ARE THEN FULLY CURED TO COATING MANUFACTURER'S SPECIFICATIONS. THE THICKNESS OF THE RESULTING FINISH AVERAGES 8-10 MILS (200-250 MICRONS).
4. IT IS NOT RECOMMENDED TO LOCATE ANCHOR BOLTS UNTIL BENCH IS IN PLACE. THIS VICTOR STANLEY, INC. PRODUCT MUST BE PERMANENTLY AFFIXED TO THE GROUND. CONSULT YOUR LOCAL CODES FOR REGULATIONS.
5. ANCHOR BOLTS NOT PROVIDED BY VICTOR STANLEY, INC.
6. FOR HIGH SALT ABUSIVE CLIMATES, HOT DIP GALVANIZING BEFORE POWDER COATING IS AVAILABLE. SEE WRITTEN SPECIFICATIONS FOR DETAILS.
7. ALL SPECIFICATIONS ARE SUBJECT TO CHANGE. CONTACT MANUFACTURER FOR DETAILS.
8. THIS PRODUCT IS SHIPPED FULLY ASSEMBLED.

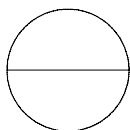

**CR-12**

CITY SITES SERIES™

BENCH WITH DUCTILE IRON END FRAMES  
 SHOWN: STANDARD 4-FOOT LENGTH