

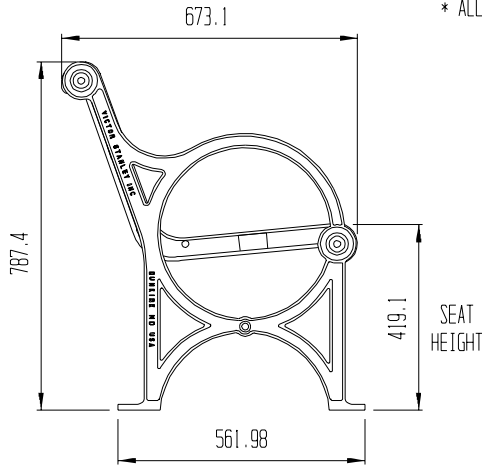

VICTOR STANLEY, INC.
-Manufacturers of Quality Site Furnishings since 1962-

P.O. DRAWER 330 - DUNKIRK, MD 20754 USA
 TOLL FREE: (800) 368-2573 (USA & CANADA)
 TEL (301) 855-8300 - FAX (410) 257-7579
 WEB SITE: HTTP://WWW.VICTORSTANLEY.COM

* ALL DIMENSIONS ARE IN MILLIMETERS *



(38) SCROLLED STEEL SLATS
 ARE FORMED FROM SECTIONS OF
 6.35 x 38.1 SOLID STEEL BARS

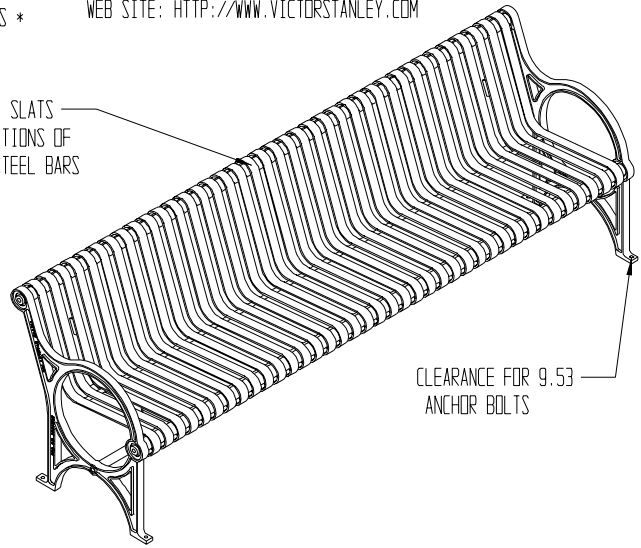

INTEGRAL WELDED CROSS-MEMBERS
 OF 47.63 TUBULAR STEEL

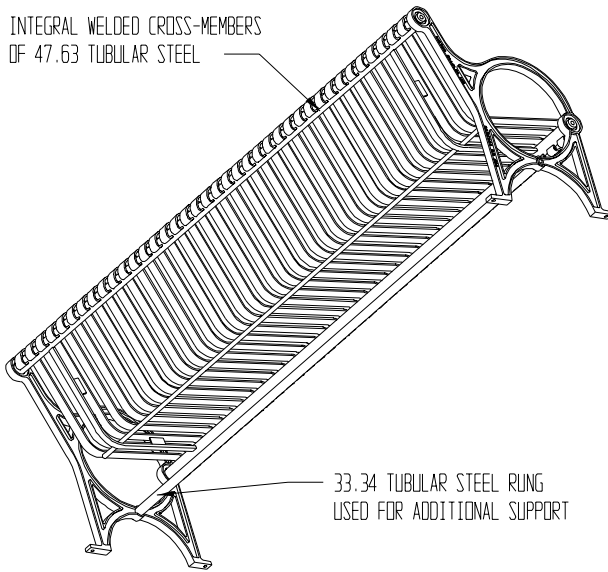

33.34 TUBULAR STEEL RING
 USED FOR ADDITIONAL SUPPORT

2495.55

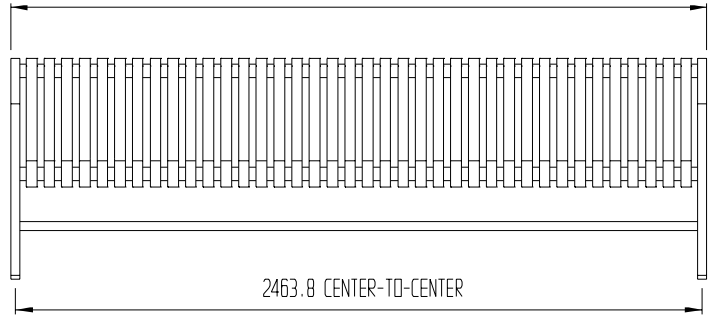

2463.8 CENTER-TO-CENTER

CENTER-TO-CENTER DISTANCES ARE APPROXIMATE
 (VARIATIONS IN CASTINGS ARISE FROM DIFFERENT RATES OF COOLING)

AVAILABLE OPTIONS:

- POWDER COATING
- 10 STANDARD COLORS, CUSTOM COLORS (INCLUDING THE RAL RANGE)

INTERMEDIATE & CENTER ARMRESTS

1.2 METERS, 1.8 METERS, & 2.4 METERS AVAILABLE WITH OPTIONAL ARMRESTS

LENGTHS

- STANDARD 1.2 METERS
- STANDARD 1.8 METERS
- STANDARD 2.4 METERS LENGTH SHOWN

NOTES:

1. DUCTILE IRON CASTINGS COME WITH A TEN YEAR WARRANTY AGAINST BREAKAGE
2. DRAWING NOT TO SCALE. DO NOT SCALE DRAWINGS.
3. ALL FABRICATED METAL COMPONENTS ARE STEEL SHOTBLASTED, ETCHED, PHOSPHATIZED, PREHEATED, AND ELECTROSTATICALLY POWDER-COATED WITH T.G.I.C. POLYESTER POWDER COATINGS. PRODUCTS ARE FULLY CLEANED AND PRETREATED, PREHEATED AND COATED WHILE HOT TO FILL CREVICES AND BUILD COATING FILM. COATED PARTS ARE THEN FULLY CURED TO COATING MANUFACTURER'S SPECIFICATIONS. THE THICKNESS OF THE RESULTING FINISH COAT AVERAGES 8-10 MILS (200-250 MICRONS).
4. IT IS NOT RECOMMENDED TO LOCATE ANCHOR BOLTS UNTIL BENCH IS IN PLACE. THIS VICTOR STANLEY, INC. PRODUCT MUST BE PERMANENTLY AFFIXED TO THE GROUND. CONSULT YOUR LOCAL CODES FOR REGULATIONS.
5. ANCHOR BOLTS NOT PROVIDED BY VICTOR STANLEY, INC.
6. FOR HIGH SALT ABUSIVE CLIMATES, HOT DIP GALVANIZING BEFORE POWDER COATING IS AVAILABLE. SEE WRITTEN SPECIFICATIONS FOR DETAILS.
7. ALL SPECIFICATIONS ARE SUBJECT TO CHANGE. CONTACT MANUFACTURER FOR DETAILS.
8. THIS PRODUCT IS SHIPPED FULLY ASSEMBLED.

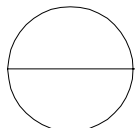

CR-12

CITY SITES SERIES

STANDARD BENCH WITH DUCTILE IRON END FRAMES
 SHOWN: STANDARD 2.4-METERS LENGTH