



CR-138 CLASSIC SERIES ASSEMBLY INSTRUCTIONS

Ref# 2007-605, revised 11-8-07 by MCW

READ ALL INSTRUCTIONS THOROUGHLY
BEFORE YOU BEGIN.

CHECK ALL PARTS

- Be certain there are no missing parts.
- Be certain all required tools are available.

REQUIRED TOOLS

- Ratchet or Breaker Bar.
- Socket 1/2-inch and Wrench 1/2-inch
- Socket 5/8-inch or 3/4-inch (dependant on which generation bench is on site.)
- Towels (or something soft) to rest components on during assembly to protect the finish

ASSISTANCE REQUIRED

- 3+ people recommended to assemble product.
- Necessary to handle, fit, and secure components.
- Heavy lifting.

All specifications are subject to change. Contact manufacturer for details.
Directions do not include center armrest attachment.

DELIVERY, STORAGE, and HANDLING

- Delivery: Deliver products to site in manufacturer's original, unopened containers and packaging. Upon delivery, examine packages immediately to ensure all products are complete and undamaged.
- Storage: Store products in a protected, dry area in manufacturer's unopened containers and packaging
- Handling: Protect product's finish from damage during handling and installation.

INSTALLATION

- Clearance for 3/8-inch (9.53mm) anchor bolts (anchor bolts not provided by Victor Stanley, Inc.)
- Mounting: It is not recommended to locate anchor bolts until bench is in place. This Victor Stanley, Inc. product must be permanently affixed to the ground. Consult your local codes for regulations.

PROTECTION

- Protect products prior to installation by having the remain in The manufacturer's packaging and container.



Should you have any problems, please contact Victor Stanley, Inc.

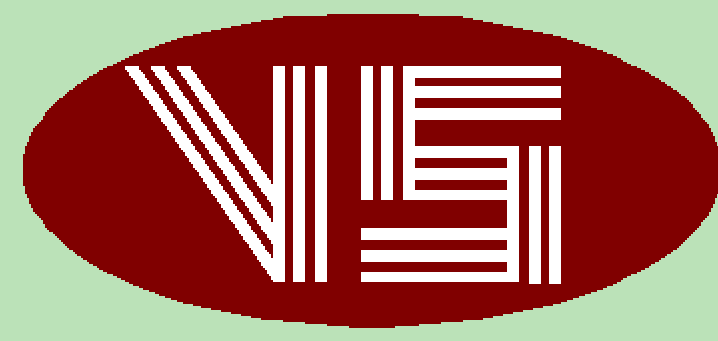

www.victorstanley.com

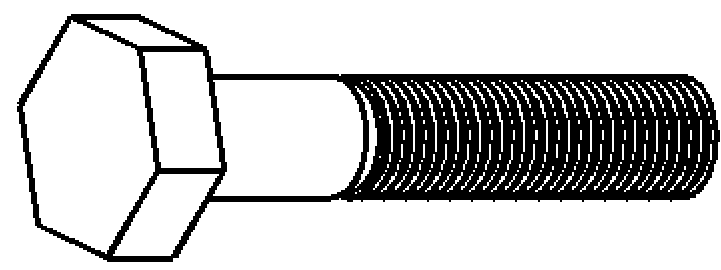
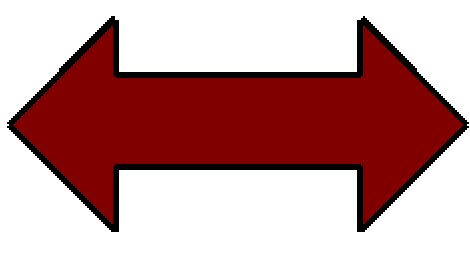
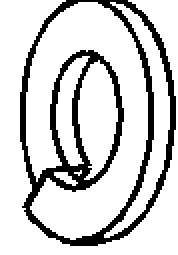
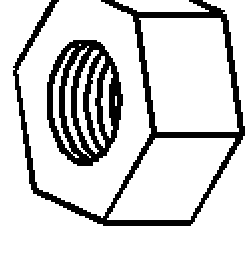
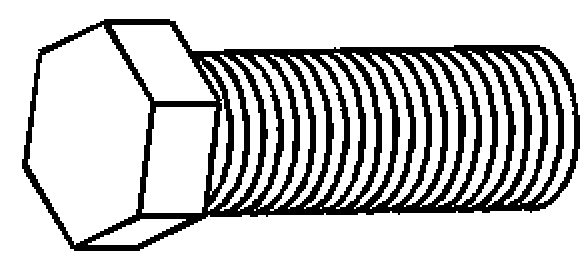
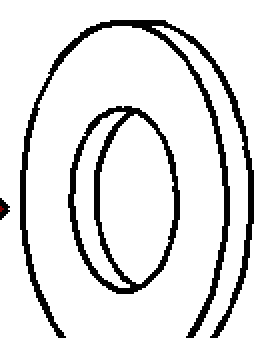
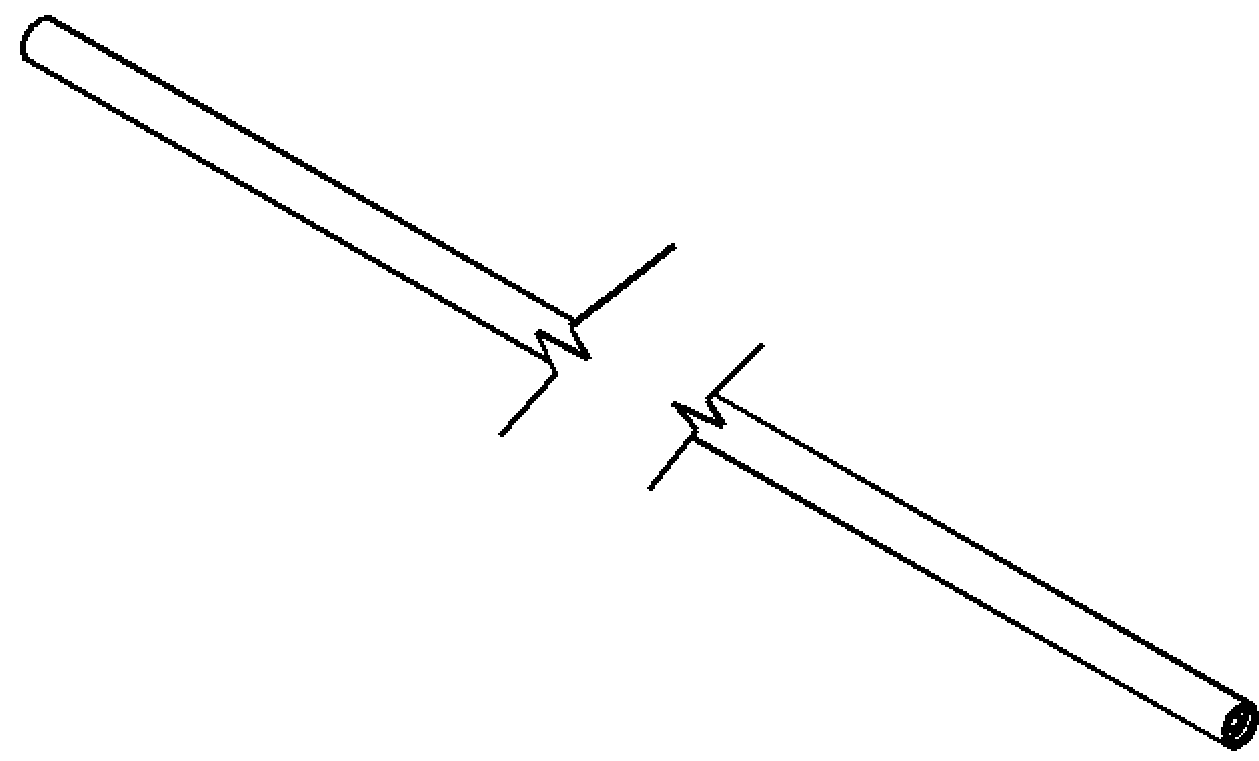
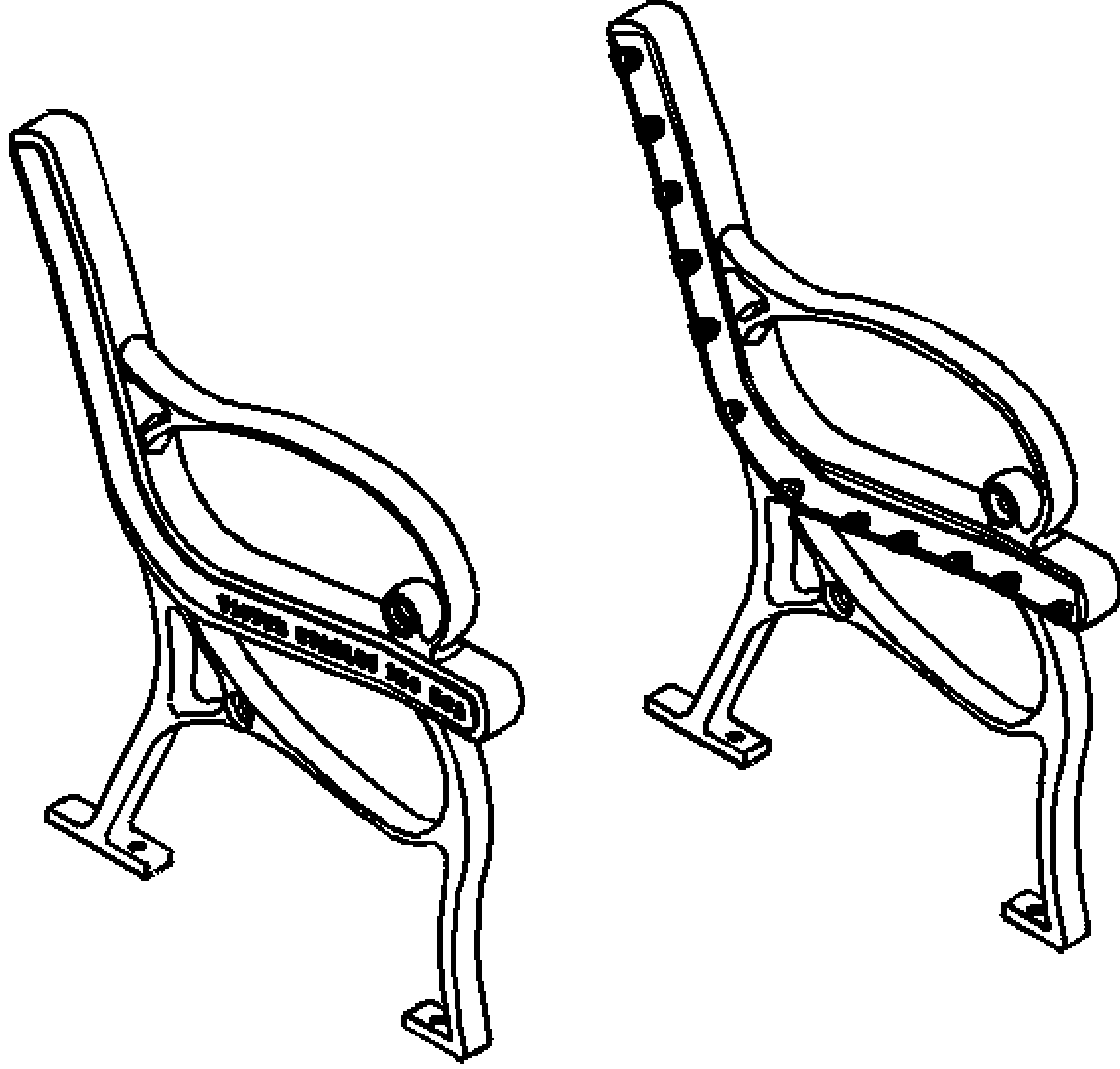
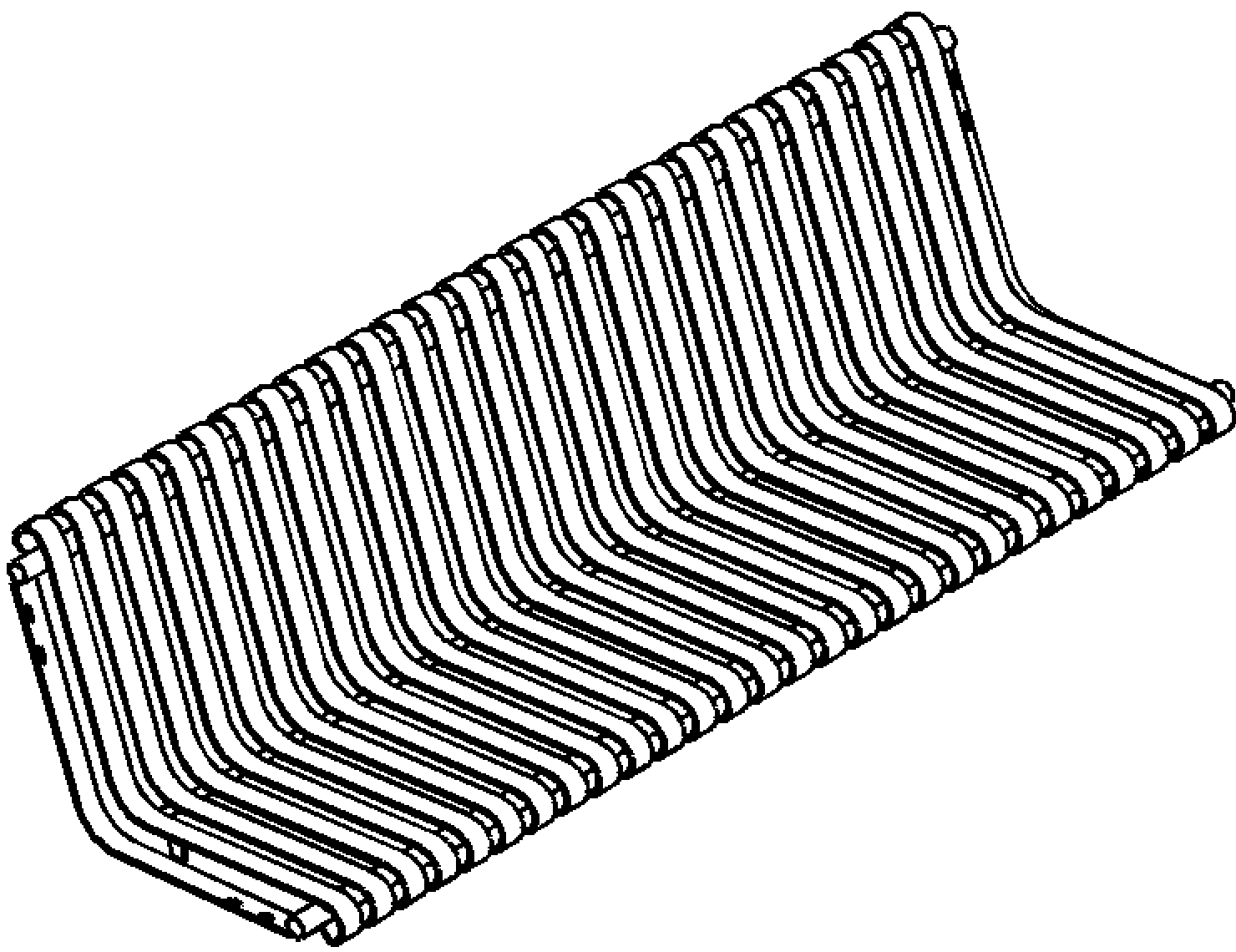

PARTS LIST

<p>Ax8 1/2-inch HEX HEAD CAP BOLT</p>  <p>Bx16 3/4-inch FLAT WASHER</p> 	<p>Cx8 5/8 inch LOCK WASHER</p> 	<p>Dx8 1/2-inch NUT</p> 	<p>Ex2 5/8-inch or 3/4-inch HEX HEAD CAP BOLT</p>  <p>Fx2 1-1/8-inch FLAT WASHER</p> 
<p>Gx1 Tubular Steel CENTER RUNG</p> 	<p>Hx1 CASTINGS (1 LEFT and 1 RIGHT)</p> 	<p>Ix1 VERTICAL STEEL SLAT SEATING SECTION</p> 	

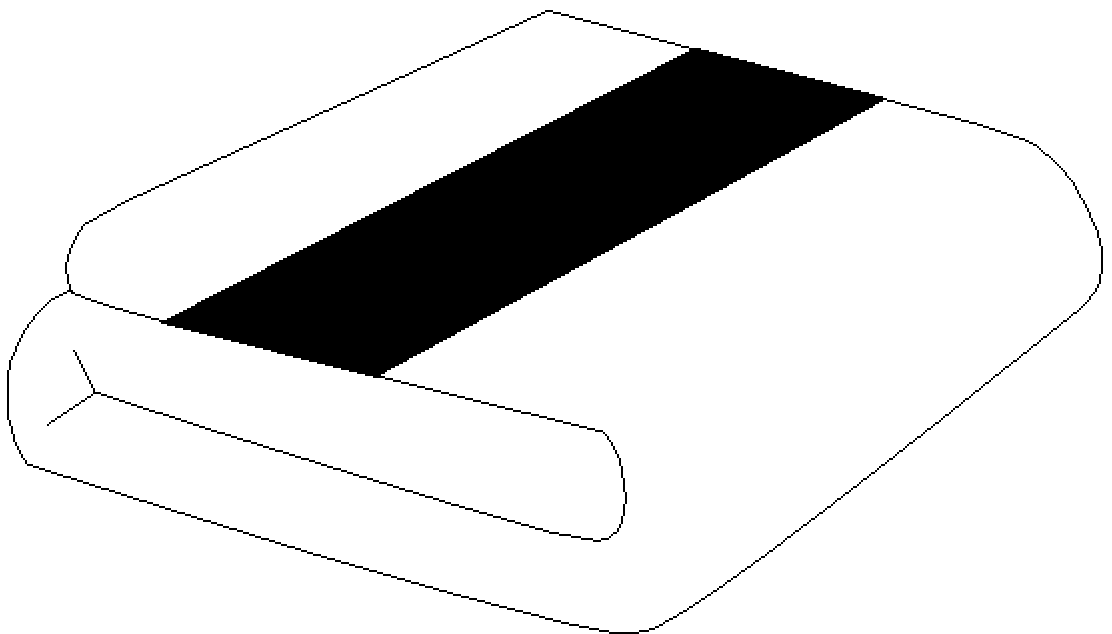
TOOLS REQUIRED (NOT PROVIDED)

 <p>1/2-inch SOCKET and 5/8-inch or 3/4-inch SOCKETS for use with RATCHET or BREAKER BAR and 1/2-inch WRENCH *This symbolizes when to use TOOL to tighten.</p>	 <p>TOWELS (or something soft to protect finish)</p>	 <p>HANDS *This symbolizes when to use HAND to tighten.</p>
---	--	--

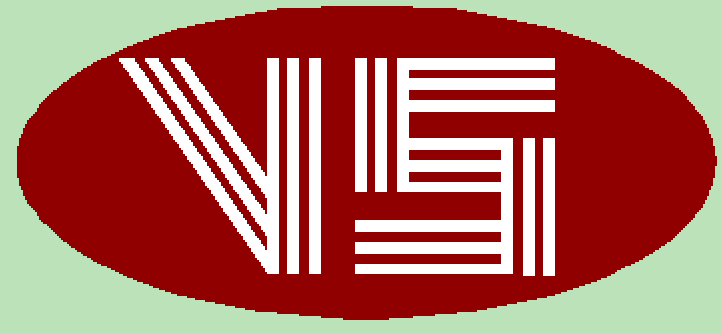

STEP #1 Remove all parts from their boxes and bags, and place on towels or a soft surface to prevent scratching (towels, cardboard, grass, ect.)

STEP #2 Have atleast two people hold up the bench seating section with spacing square, and support rod facing down as shown.

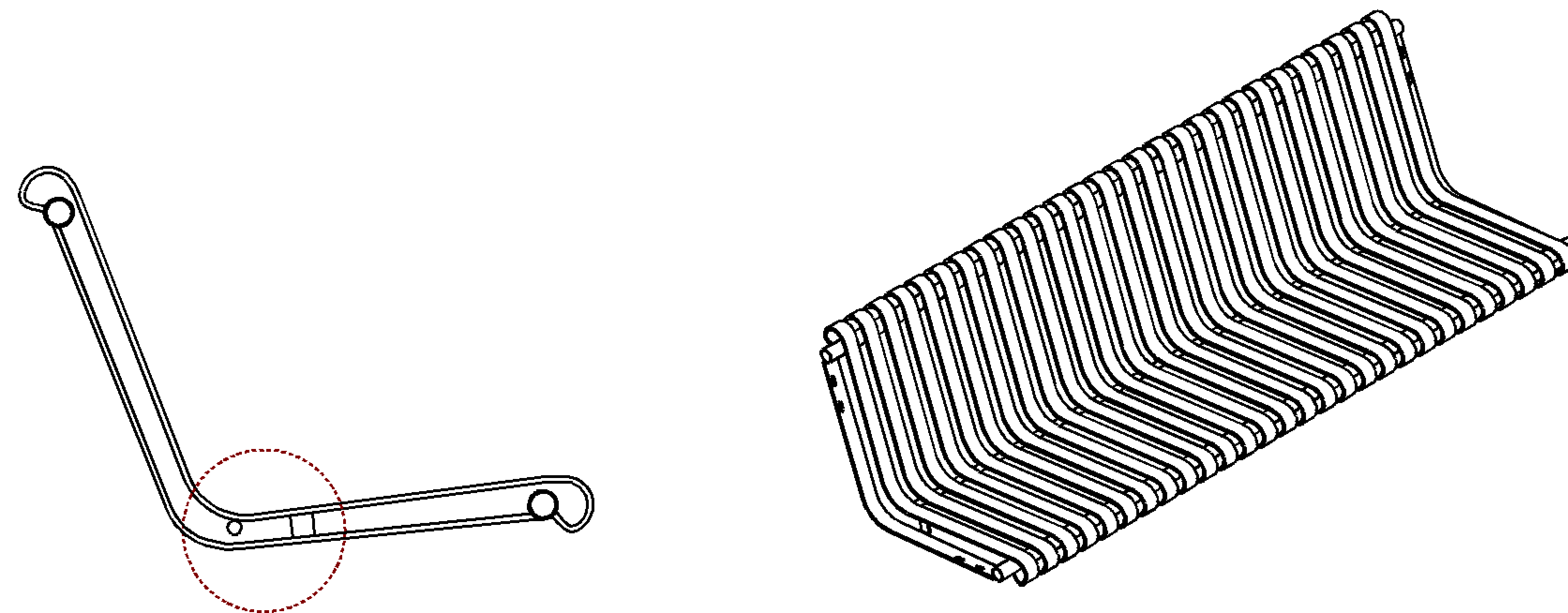

STEP #3 Have another person slide the right side casting into place. Bolt the front of the seat, and the top of the back to hold the casting in place. The slots in the brace should align with the 2nd and 3rd holes in the casting for both the back and the seat.

For step 3, 4, AND 5 use Bolt Assembly as shown:

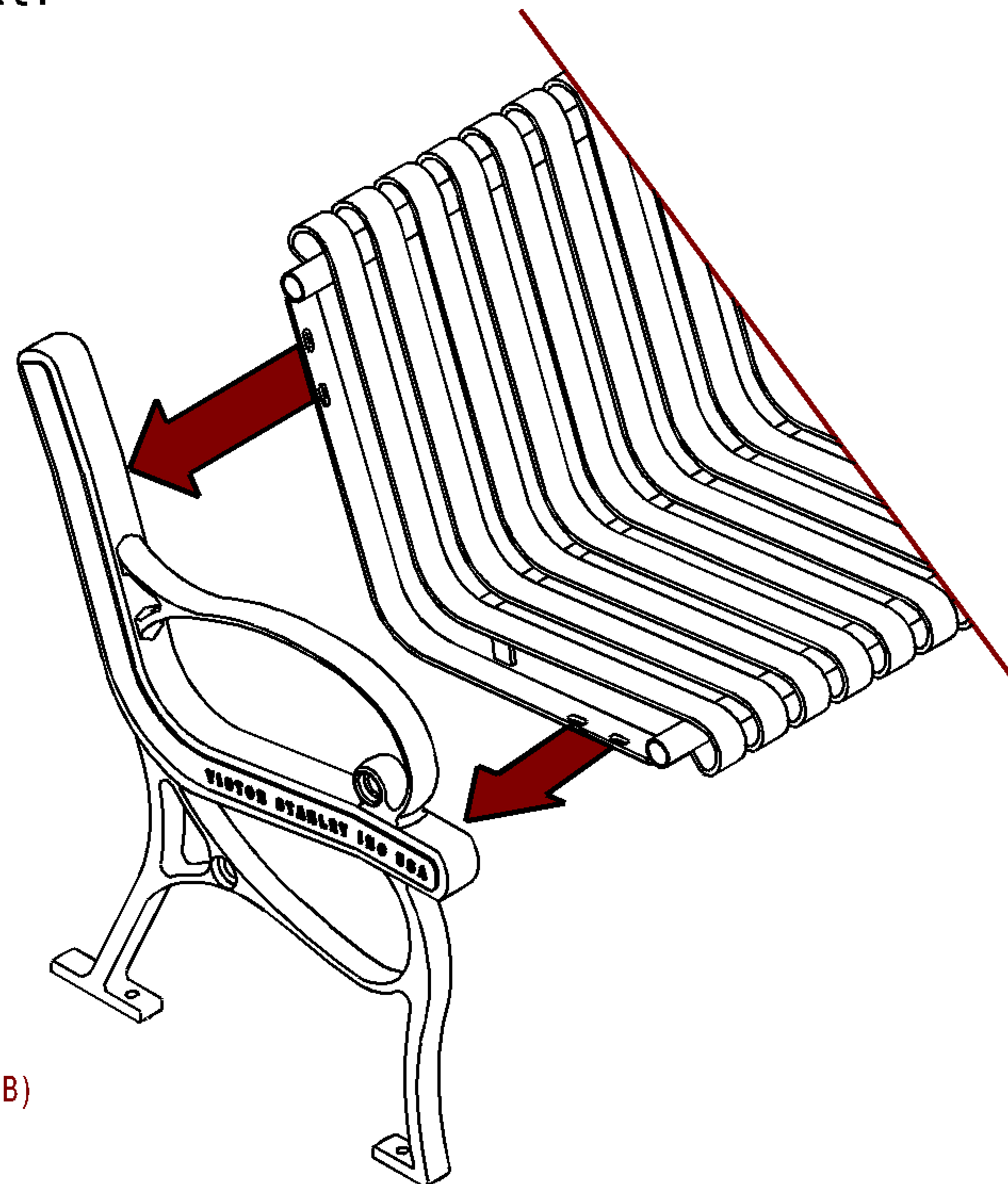
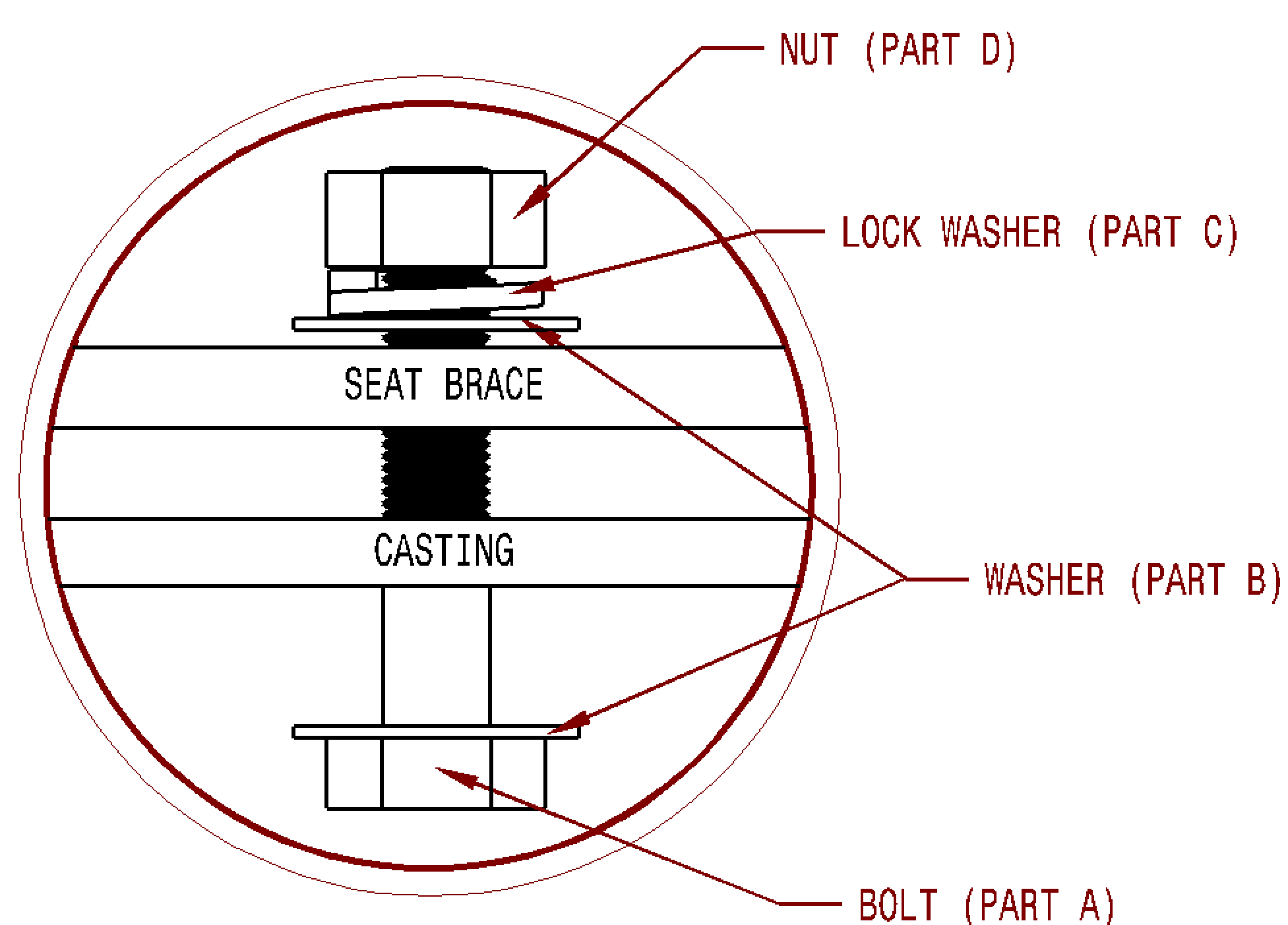

HAND TIGHTEN

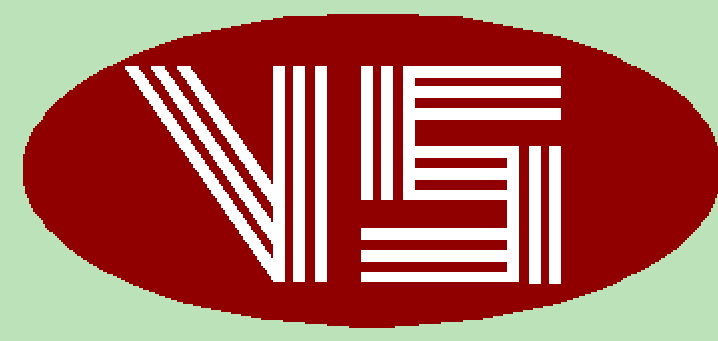

STEP #4 Repeat Step #3 with the left casting. Once you have the first two bolts in place, the people holding the seating section can release the weight onto the castings.

STEP #5 Make sure everything is straight before fastening the remaining bolts.

STEP #6 Place the rung between both end frames. Attach the rung with bolt combination (parts E & F) as shown.



**HAND TIGHTEN
STEPS 4-6**

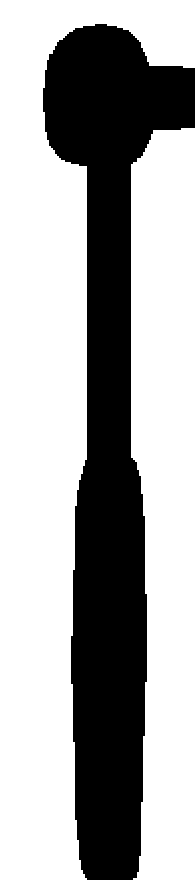
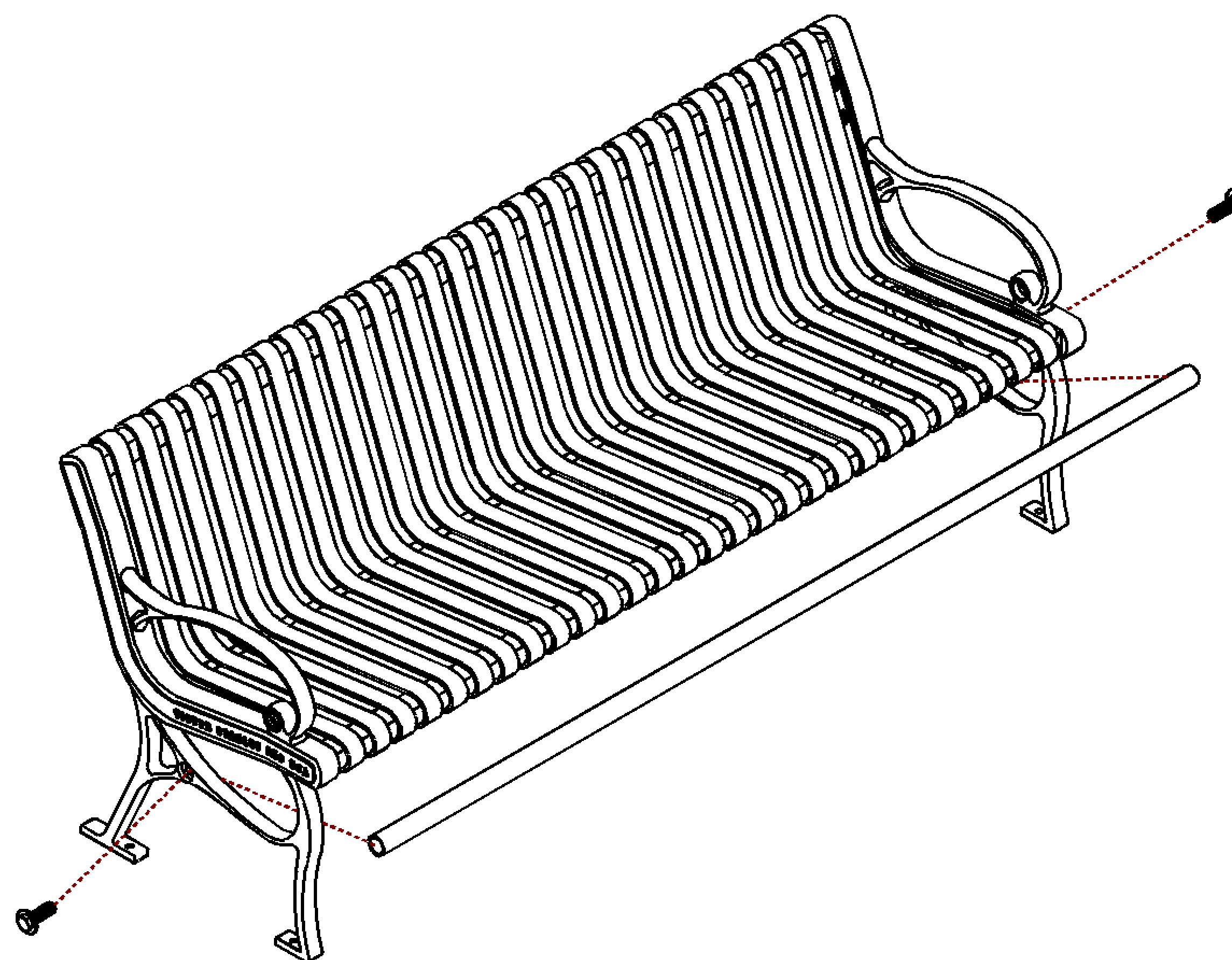
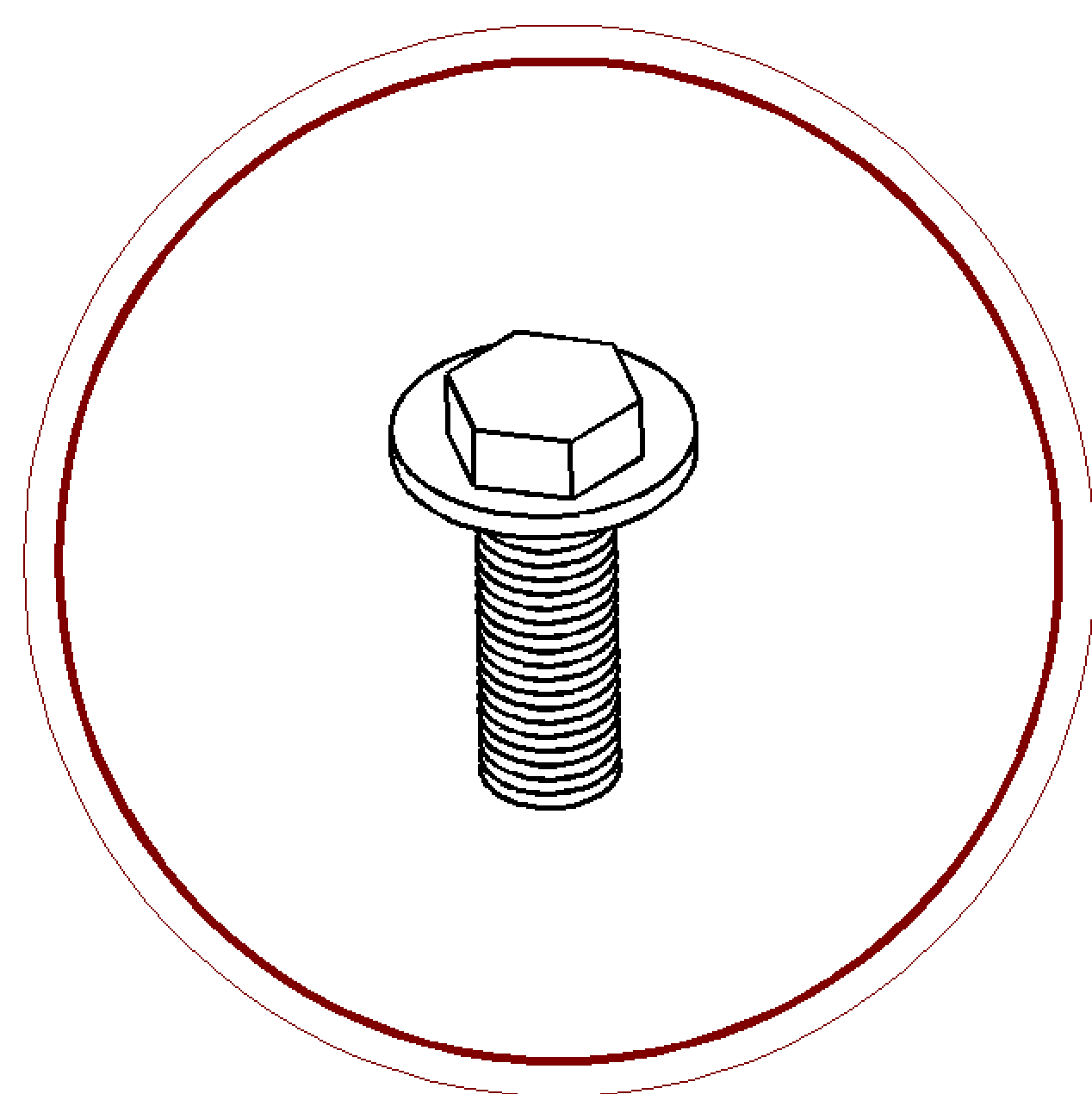

**TOOL TIGHTEN
STEPS 8 & 9**

STEP #7 Carefully inspect the bench from front and back to ensure the legs of the bench are standing straight.

STEP #8 Once everything is straight and aligned properly, tighten the Bolts connecting the castings and the seating section. While tightening have someone make sure that the bench remains straight and aligned.

STEP #9 Tighten the two bolts on the rung.

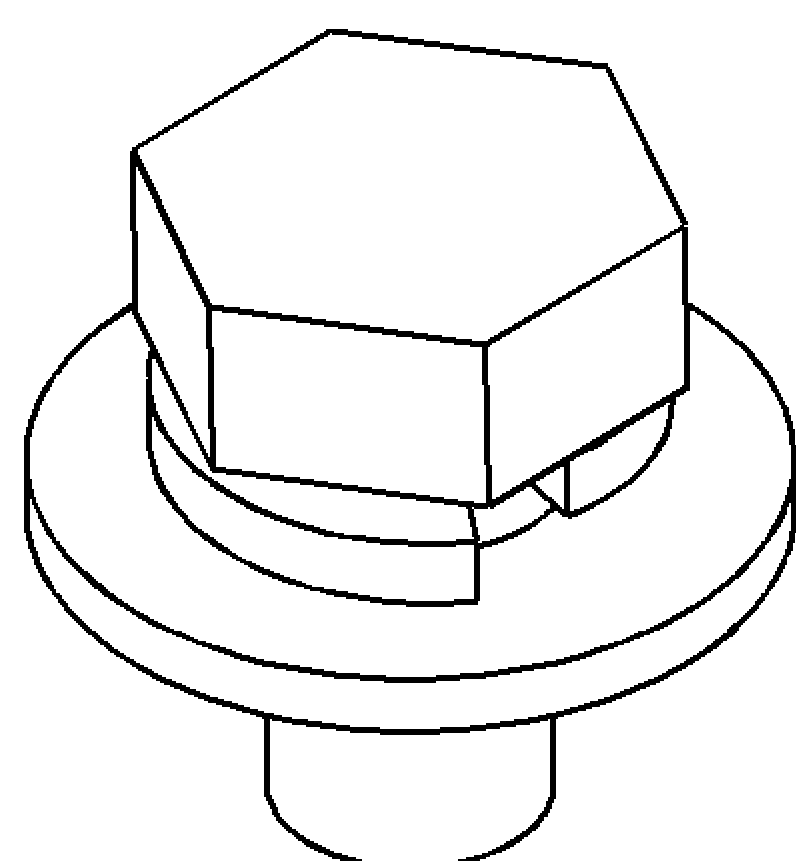

Lock washer when
HAND tightened

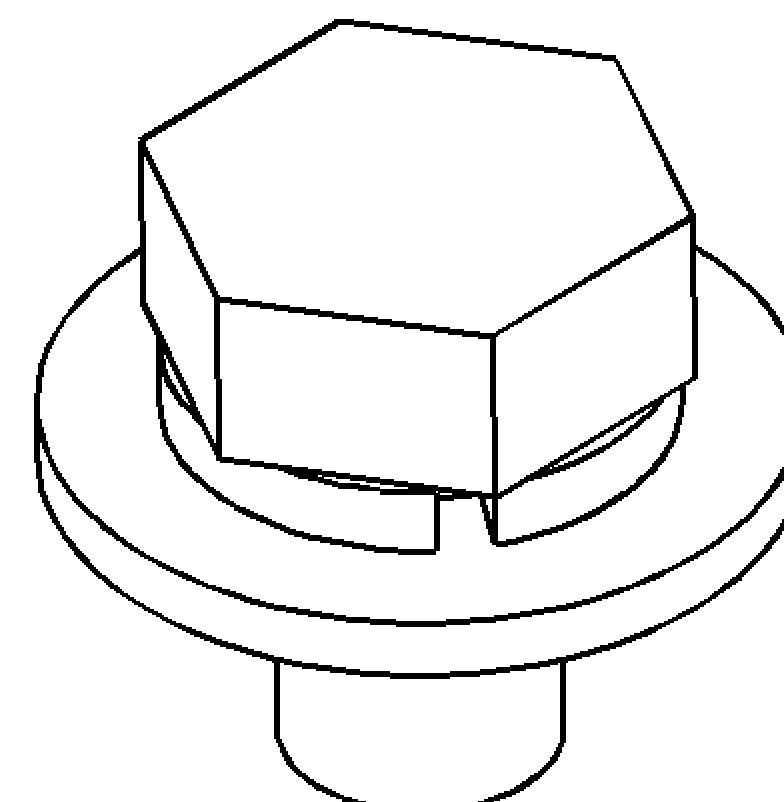

Lock washer when
TOOL tightened
DO NOT OVER TIGHTEN



VICTOR STANLEY, INC.
-Manufacturers of Quality Site Furnishings since 1962-

CR-138 CLASSIC SERIES
ASSEMBLY INSTRUCTIONS

PAGE 5 of 5

CR-138 CLASSIC SERIES FINAL PRODUCT

