



Create a timeless moment.®

* ALL DIMENSIONS ARE IN INCHES *

P.O. DRAWER 330 - DUNKIRK, MD 20754 USA
 TOLL FREE: (800) 368-2573 (USA & CANADA)
 TEL (301) 853-8300 - FAX (410) 257-7579
 WEB SITE: HTTP://WWW.VICTORSTANLEY.COM

THIS PRODUCT IS COVERED BY ONE OR MORE OF THE FOLLOWING
 U.S. PATENTS D710,139 S ; D710,625

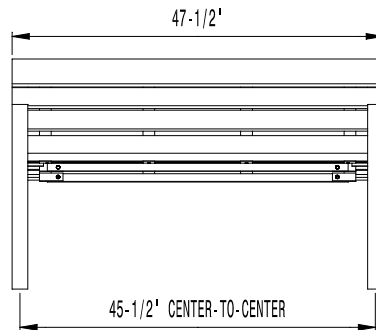
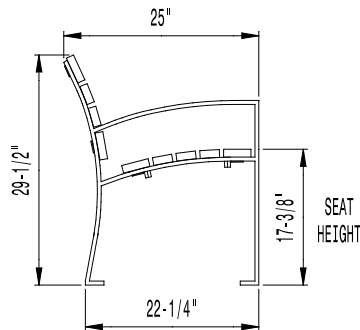
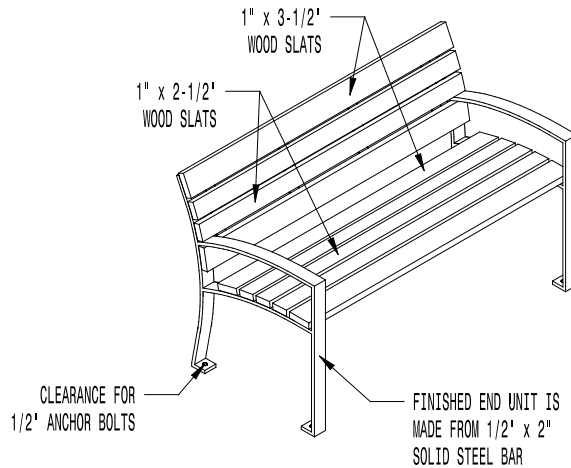

AVAILABLE OPTIONS:

POWDER COATING

10 STANDARD COLORS, 2 OPTIONAL METALLIC COLORS,
 CUSTOM COLORS (INCLUDING THE RAL RANGE)

INTERMEDIATE ARMRESTS (BOLT-ON)

4', 6', & 8' AVAILABLE WITH OPTIONAL ARMRESTS

LENGTHS

- STANDARD 2'
- STANDARD 4' (AS SHOWN)
- STANDARD 6'
- STANDARD 8'

MOUNTING

STANDARD SURFACE (AS SHOWN) AND IN-GROUND

NOTES:

1. DRAWINGS NOT TO SCALE. DO NOT SCALE DRAWINGS.
2. ALL FABRICATED METAL COMPONENTS ARE STEEL SHOTBLASTED, ETCHED, PHOSPHATIZED, PREHEATED, AND ELECTROSTATICALLY POWDER-COATED WITH T.G.I.C. POLYESTER POWDER COATINGS. PRODUCTS ARE FULLY CLEANED AND PRETREATED, PREHEATED AND COATED WHILE HOT TO FILL CREVICES AND BUILD COATING FILM. COATED PARTS ARE THEN FULLY CURED TO COATING MANUFACTURER'S SPECIFICATIONS. THE THICKNESS OF THE RESULTING FINISH AVERAGES 8-10 MILS (200-250 MICRONS).
3. IT IS NOT RECOMMENDED TO LOCATE ANCHOR BOLTS UNTIL BENCH IS IN PLACE. THIS VICTOR STANLEY, INC. PRODUCT MUST BE PERMANENTLY AFFIXED TO THE GROUND. CONSULT YOUR LOCAL CODES FOR REGULATIONS.
4. ANCHOR BOLTS NOT PROVIDED BY VICTOR STANLEY, INC.
5. FOR HIGH SALT ABUSIVE CLIMATES, HOT-DIP GALVANIZING BEFORE POWDER COATING IS AVAILABLE. HOT-DIP GALVANIZING IS PERFORMED FOR VICTOR STANLEY, INC. BY AN EXPERIENCED QUALIFIED FIRM TO WHICH PRODUCTS ARE SHIPPED FOR GALVANIZING. HOT-DIP GALVANIZING INCLUDES AN AGGRESSIVE PRE-TREATMENT AND IMMERSION IN A TANK OF CHARGED LIQUID ZINC AT OR AROUND 860°F (460°C). THE RESULTING SURFACE IS RESISTANT TO RUST BUT HAS SOME UNEVENNESS RESULTING FROM THE BONDING OF THE ZINC TO THE STEEL SURFACE. AS A RESULT, THE POWDER-COATING SURFACE FINISH OVER THAT GALVANIZED SURFACE MAY EXHIBIT BUMPS, UNEVENNESS, AND MAY NOT BE AS SMOOTH AS THE STANDARD FINISH; THIS UNEVEN AND INCONSISTENT FINISH IS NORMAL FOR GALVANIZING. CONTACT MANUFACTURER FOR DETAILS.
6. ALL SPECIFICATIONS ARE SUBJECT TO CHANGE. CONTACT MANUFACTURER FOR DETAILS.
7. THIS PRODUCT IS SHIPPED PARTIALLY UNASSEMBLED.

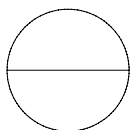

EVA-20-W

REVERIE

EVA BACKED BENCH WITH WOOD SLATS
 SHOWN: STANDARD 4-FOOT LENGTH
 STANDARD SURFACE MOUNT