



FBF-50 STREETSITES SERIES™ ASSEMBLY INSTRUCTIONS

PAGE 1 OF 5

Ref# 2012-359, revised 4-23-12 by SMP

READ ALL INSTRUCTIONS THOROUGHLY
BEFORE YOU BEGIN.

CHECK ALL PARTS

- Be certain there are no missing parts.
- Be certain all required tools are available.

REQUIRED TOOLS

- Driver for 5/32-inch (dependent on which generation bench is on-site.)
- Towels (or something soft) to rest components on during assembly to protect the finish

ASSISTANCE REQUIRED

- 4 people recommended to assemble product.
- Necessary to handle, fit, and secure components.
- Heavy lifting.

All specifications are subject to change. Contact manufacturer for details.

DELIVER, STORAGE, and HANDLING

- Delivery: Deliver products to site in manufacturer's original, unopened containers and packaging. Upon delivery, examine packages immediately to ensure all products are complete and undamaged.
- Storage: Store products in a protected, dry area in manufacturer's unopened containers and packaging
- Handling: Protect product's finish from damage during handling and installation.

INSTALLATION

- Clearance for ½-inch (13mm) anchor bolts (anchor bolts not provided by Victor Stanley, Inc.)
- Mounting: It is not recommended to locate anchor bolts until bench is in place. This Victor Stanley, Inc. product must be permanently affixed to the ground. Consult your local codes for regulations.

PROTECTION

- Protect products prior to installation by having them remain in The manufacturer's packaging and container.







Should you have any problems, please contact Victor Stanley, Inc.

WWW.VICTORSTANLEY.COM

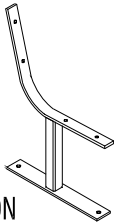
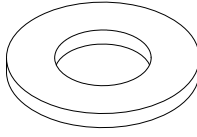
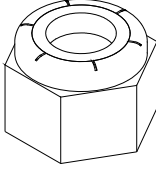
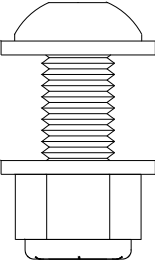
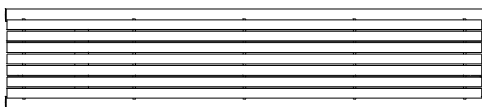

PARTS LIST

<p>Ax8</p>  <p>1/2" x 1-1/2" HH CIS FINISHED BOLT</p>	<p>5/32-inch HEX DRIVE BIT</p> 	<p>Hx2</p>  <p>SEAT SECTION SUPPORT ASSY</p>
<p>Dx16</p>  <p>SEAT SECTION SUPPORT ASSY</p>	<p>Ex8</p>  <p>1/2" 13 SS FINISHED NUT</p>	 <p>EXAMPLE CONFIGURED FOR USE</p>
<p>Hx2</p>  <p>SEAT SECTIONS</p>		
		

TOOLS REQUIRED (NOT PROVIDED)

 <p>*This symbolizes when to use TOOL to tighten.</p>	 <p>2 TOWELS (or something soft to protect finish)</p>	 <p>This symbolizes when to use HAND to tighten</p>
--	---	--



DIAGRAM A

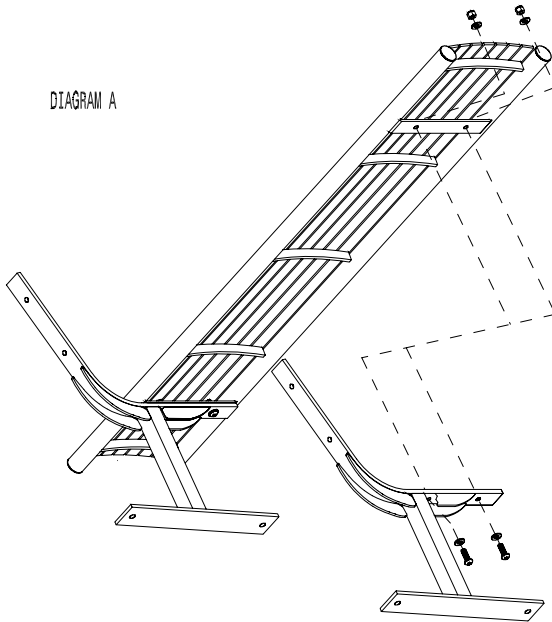

STEP #1 Remove all parts from their boxes and bags and place on towels or other soft surface to prevent scratching (towels, cardboard, grass, etc.)

STEP #2 Have one person hold up each leg and seat support assembly. Have the third and fourth persons bring the lower seat section and place it on the seat support assembly. Align the seat section brace holes with the seat assembly support holes and bolt in place using parts A, D, and E as shown in Diagram A. Repeat this process for the seat back section as shown in Diagram B.

STEP #3 HAND TIGHTEN ALL NUTS AND BOLTS

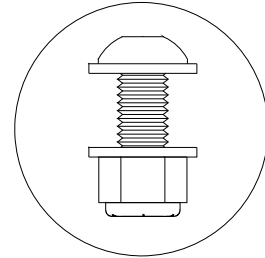
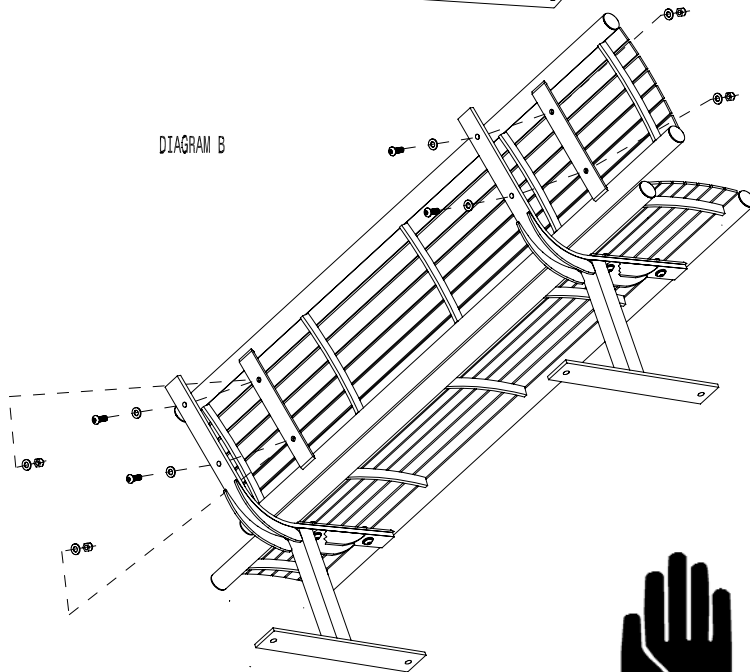
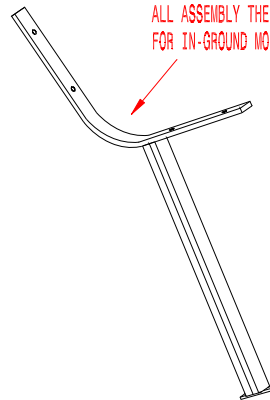

DIAGRAM B



ALL ASSEMBLY THE SAME
FOR IN-GROUND MOUNT





VICTOR STANLEY, INC.
-Manufacturers of Quality Site Furnishings since 1962-

FBF-50 STREETSITES SERIESSM
ASSEMBLY INSTRUCTIONS
PAGE 4 OF 5

STEP #4 ALIGN AND TOOL TIGHTEN ALL NUTS AND BOLTS

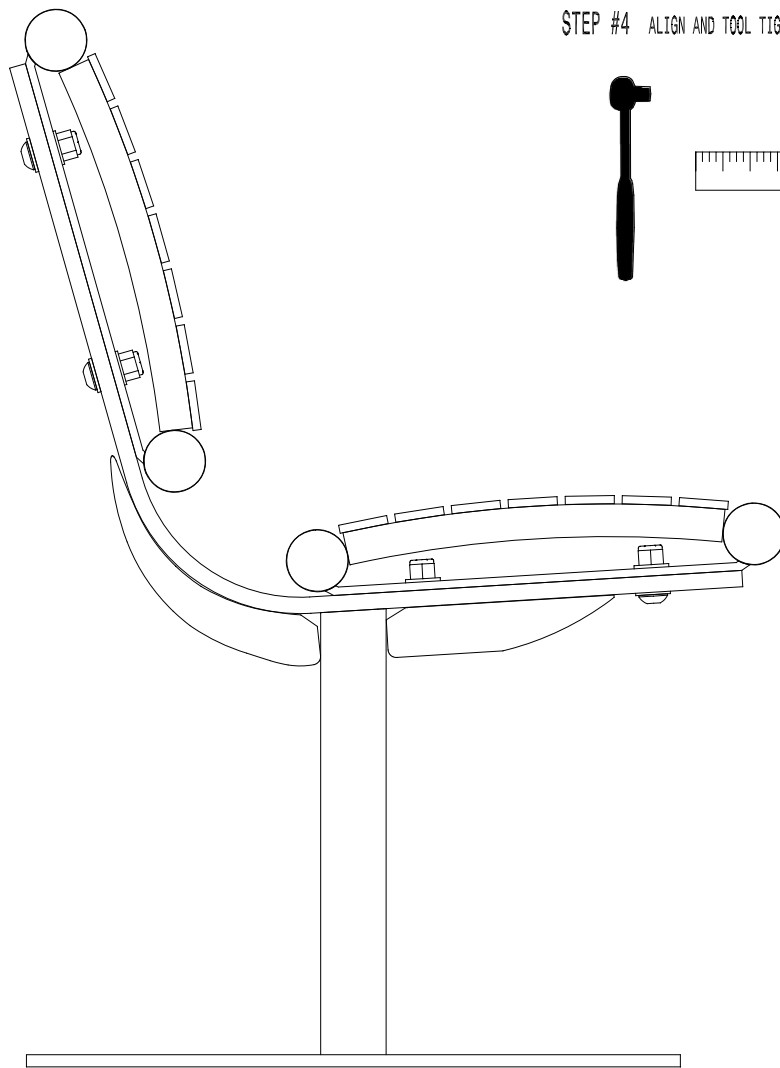



VICTOR STANLEY, INC.
-Manufacturers of Quality Site Furnishings since 1962-

FBF-50 STREETSITES SERIES™
ASSEMBLY INSTRUCTIONS
PAGE 5 OF 5

Finished Product

