



US Patents D710,624 S;
D710,626 S; D711,175 S;
D711,176 S; D726,473 S;
D726,474 S; D727,669 S.

The perfect escape since 1962.

Celebrating over 60 years, Victor Stanley designs, engineers and manufactures timeless site furnishings so you can bring communities to life. Our Perenne collection (patented) embodies elements in nature and classical settee furniture design while remaining slim, open, functional, and timeless.

VICTOR  STANLEY®

Create a timeless moment.®

Designed, engineered, and manufactured with the same attention to detail, quality, and durability that the design community has come to expect from Victor Stanley. The Perenne collection features clean lines, natural proportions, and slim profiles. The Freesia bench (patented) embodies elements in nature and classical settee furniture design while remaining open and functional. It's just one more way Victor Stanley helps you create the perfect setting for timeless moments.

FREESIA BENCH

2, 4 or 6 ft (1.2 or 1.8 m) length.

Model FRE-20: with end armrests.*

Model FRE-20NA: without armrests.*

OPTIONS

Horizontal steel slat seating. Wood slat seating. Surface mount.

In-ground mount. Intermediate armrests.

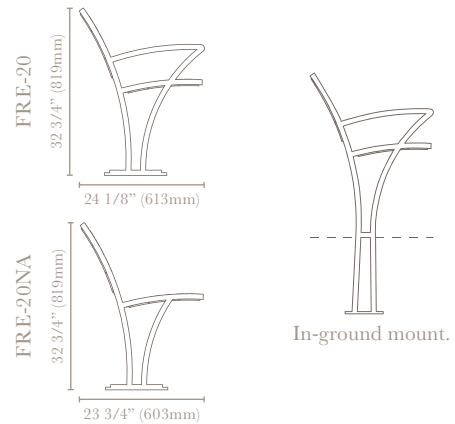

FREESIA BACKLESS BENCH

2, 4 or 6 ft (1.2 or 1.8 m) length.

Model FRE-23: with end armrests.*

Model FRE-23NA: without armrests.

OPTIONS

Horizontal steel slat seating. Wood slat seating. Surface mount.

In-ground mount. Intermediate armrests.

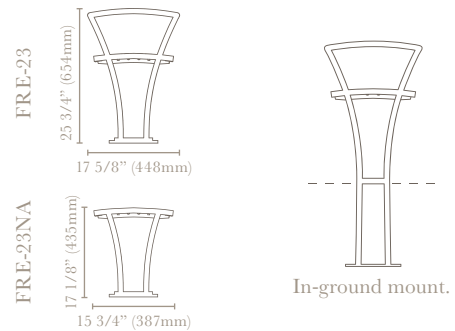

FREESIA BIKE RACK

Frame constructed of 1 x 1 in (25.4 x 25.4 mm) solid steel.

Capacity: 2 bikes.

Model BFRE-101: single arch.*

Model BFRE-161: single arch with cross bar.*

OPTIONS

Surface mount. In-ground mount.

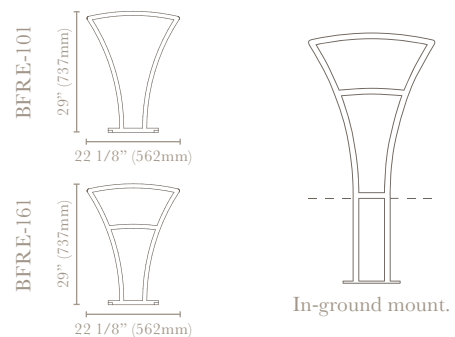

*Covered by one or more of the following: US Patents D710,624 S; D710,626 S; D711,175 S; D711,176 S; D726,473 S; D726,474 S; D727,669 S.

See product specifications for further details. Drawings are not to scale. Our TGIC powder-coating averages 8-10 mils (200-250 microns) thick and is applied in-house to ensure the highest level of quality. Offered in 15 standard, satin and metallic colors, plus a full range of RAL colors with available color matching. Additional cost may apply.



Wood slat seating.
Patented.*



Steel slat seating.
Optional yellow green.
Patented.*



Wood slat seating.



In-ground mount.
Patented.*



Surface mount.
Patented.*



Steel slat seating.
Patented.*

Victor Stanley, a leader in quality site furnishings, helps you bring your visions to life. From benches and bike racks to smart litter receptacles, which use our Relay® Sensor and Service to enable efficient collection routing, we meticulously design, engineer and manufacture every detail to ensure our site furnishings will withstand the test of time. Celebrating over 60 years, we have helped create a place for people to gather, live life and make timeless moments.



Create a timeless moment.®