

\* ALL DIMENSIONS ARE IN INCHES \*

- 1 - REMOVE ALL PARTS FROM THEIR BOXES AND BAGS. PLACE ON TOWELS OR A SOFT SURFACE TO PREVENT SCRATCHING.
- 2 - USING THE PROVIDED HEX HEAD BOLT AND CORRESPONDING HARDWARE IN THE CONFIGURATION SHOWN, ATTACH THE TABLE LEG TO THE TABLE TOP. HAND TIGHTEN ALL HARDWARE.

DO NOT FULLY TIGHTEN

HARDWARE CONFIGURATION

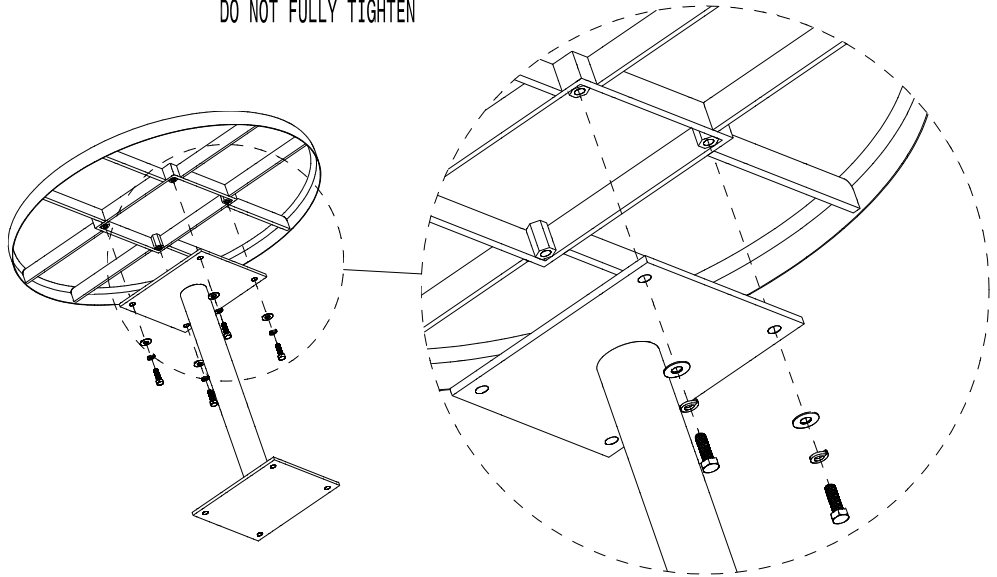
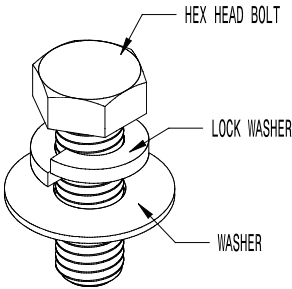

- 3 - USING THE PROVIDED CARRIAGE BOLT AND CORRESPONDING HARDWARE IN THE CONFIGURATION SHOWN, ATTACH THE SEAT LEG TO THE SEAT SECTION. HAND TIGHTEN ALL HARDWARE. REPEAT FOR REMAINING SEAT SECTIONS.

DO NOT FULLY TIGHTEN

HARDWARE CONFIGURATION

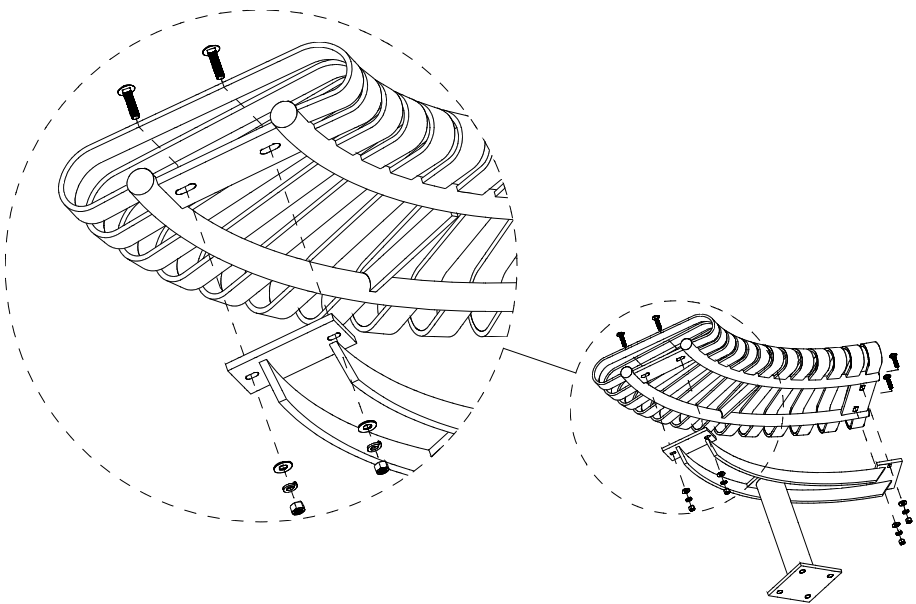
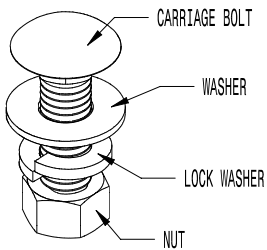

ALL STEEL TABLE AND SEAT COMBINATION  
 SHOWN: GENERAL ASSEMBLY INSTRUCTIONS

\* ALL DIMENSIONS ARE IN INCHES \*

4 - ONCE THE TABLE AND SEATS ARE FULLY ASSEMBLED, MAKE SURE EVERYTHING IS PROPERLY SPACED AND ALIGNED. TOOL TIGHTEN ALL HARDWARE. BOLTS SHOULD BE TIGHTENED UNTIL LOCK WASHERS COMPRESS (AS SHOWN).

BOLT & FASTENER  
BEFORE TOOL TIGHTENING

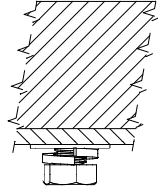
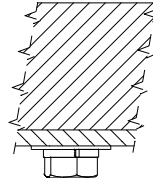
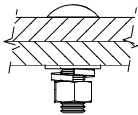

TABLE HARDWARE



BOLT & FASTENER  
AFTER TOOL TIGHTENING



SEAT HARDWARE

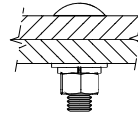

**DO NOT OVER TIGHTEN.**

**FINAL PRODUCT**

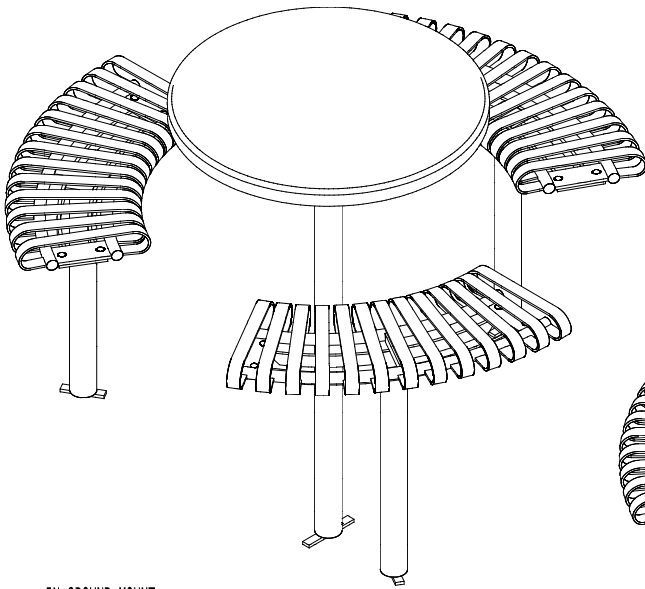

IN-GROUND MOUNT

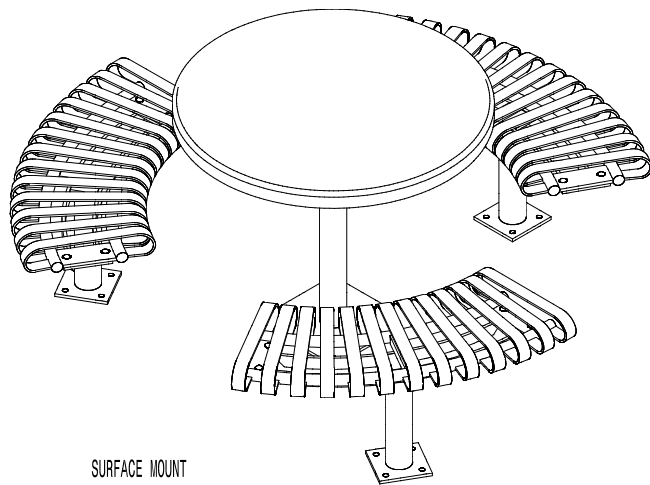

SURFACE MOUNT



ALL STEEL TABLE AND SEAT COMBINATION  
 SHOWN: GENERAL ASSEMBLY INSTRUCTIONS